

Optical Fiber Arc Fusion Splicer

Read this user manual carefully before running KF4A

SWIFT KF4A

USER MANUAL

SWIFT KF4A-EN, Rev.C

This device complies with Part 15 of the FCC Rules. Operation is subject to the following two conditions: (1) This device may not cause harmful interference, and (2) this device must accept any interference received, including interference that may cause undesired operation.

Device Type	Notification
A Class Device (Broadcasting and communication device, commercial use)	Users need to understand that this device(A Class) has obtained EMI(Electromagnetic compatibility) and been designed to be used in places other than home.

Contents

1. SAFETY INSTRUCTIONS	5
2. PRODUCT SPECIFICATIONS AND COMPONENT	8
2.1 PRODUCT SPECIFICATIONS	8
2.2 PRODUCT PACKAGE	9
3. PRODUCT OUTLINE	10
3.1 FUNCTION BUTTONS	10
3.2 COMPONENT NAME	11
4. INSTRUCTIONS FOR USE	13
4.1 POWER SUPPLY	13
4.2 HOW TO TURN THE POWER ON/OFF	14
4.3 FIBER CLEANING	15
4.4 INSERTING FIBER TO PROTECTING SLEEVE	15
4.5 FIBER STRIPPING	16
4.6 FIBER CLEANING	19
4.7 FIBER CLEAVING	20
4.8 KF4A SLEEVE-HEATER	25
4.9 SPLICE PROCEDURE	27
4.10 REMOVING THE SPLICED FIBER	28
4.11 HEATING PROTECTION SLEEVE	28
4.12 USE OF WORK BELT	29
5. MAINTENANCE OF SPLICE QUALITY	30
5.1 CLEANING AND INSPECTION BEFORE SPLICE	30
5.2 REGULAR INSPECTION AND CLEANING	32

6. MENU	34
<hr/>	
POPUP MENU	37
6.1 SPLICE	44
6.2 HEATER	52
6.3 STRIPPER	57
6.4 HISTORY (SPLICE RESULT)	61
6.5 OPTION	63
6.6 OPTICAL MODULE	67
6.7 CALIBRATION	69
6.8 ELECTRODES	75
6.9 SETTING	78
6.10 INFORMATION	81
7. ERROR MESSAGE	84
<hr/>	
7.1 TOO DIRTY FIBER	84
7.2 REPLACE FIBER.	84
7.3 TOO LONG FIBER.	85
7.4 FIBER OVER ANGLE	85
7.5 LOSS LIMIT OVER	86
7.6 FIBER THIN ERROR	86
7.7 FIBER THICK ERROR	86
7.8 BUBBLE ERROR	86
7.9 CLEAVED SURFACE ERROR	86
8. SPLICING PROBLEM SOLVING	87
<hr/>	
8.1 WHEN LOSS IS HIGH	87
8.2 ABNORMAL SPLICING OPERATION	87
9. PROBLEM OCCURRENCE AND QUESTION	88
<hr/>	
9.1 POWER	88



9.2	SPLICE	89
9.3	SLEEVE HEATER	90
9.4	OTHERS	90
10.	WARRANTY AND REPAIR	91
<hr/>		
	RESPONSIBILITY LIMIT	91
10.1	INFORMATION NECESSARY FOR REPAIR	91
10.2	TRANSPORTATION	91
10.3	REPAIR	91

1. Safety Instructions

The KF4A is designed for convenient use on indoor and outdoor work sites. Please read all instructions to prevent accidents and malfunctions. This user guide provides the information necessary for safe operation.

Keep this user guide with the product at all times.

UCLSwift does not take any responsibility for equipment damage and personal or physical loss incurred due to improper use or alteration.

WARNINGS

If any of the following situations occur during use, turn off the power immediately and contact your local UCLSWIFT office or representative:

- Smoke, abnormal smell, noise or abnormal overheating
- A foreign substance or liquid falls into the equipment
- The splicer is visibly damaged

Use only the power cord and connecting devices provided with or intended for the KF4A. Failure to do so may result in fire, electrical shock or injury.

Do not touch the electrodes when the power is on. High voltage and high temperatures generated from the electrodes may result in serious shock or burn.

Connect the provided AC power cord only as directed. Ensure that there is no foreign substance on the terminal before connecting it to the AC power socket.

Improper use may result in smoke, electrical shock, fire, equipment damage, serious injury or even death.

Use proper power voltage.

AC power for the charger is AC100-240V, 50~60 Hz.

Test the AC power before use. When the output voltage of AC power is high, or abnormal frequency is generated, the product is damaged; serious injury or even death may result.

AC output voltage should be measured using a circuit tester before connecting the AC power cable; regular inspection should also be conducted.

Do not pull the AC power cord with excessive force, apply heat or transform it.

When a damaged power cord is used, it may cause fire or injury.

Use a three-plug AC power cord. Never use a two-plug power cord, cable or plug.

WARNINGS

Do not touch the AC plug, AC power cord or splicer with wet hands. It may cause electrical shock.

Do not disassemble the AC charger, battery or KF4A. Deformation may cause fire, electrical shock or injury.

Refer to the following when using the battery:

- Failure to use batteries and chargers provided by UCLSWIFT may result in smoke, equipment damage, burn, injury or even death.
- Do not incinerate any conductive materials.
- Do not charge the battery near flame.
- Do not give an excessive shock to the battery.
- When the battery does not completely charge in two hours, or when the green LED is not turned on, stop charging immediately and contact UCLSWIFT.
- Do not put anything on the AC charger while charging.

Use only the AC charger provided. Do not use another AC power cord or battery. Excessive current may result in equipment damage or injury.

Do not use the KF4A where there is harmful gas or flammable liquid. Explosion or fire may result.

Do not use compressed air or compressed gas when cleaning the KF4A.

To inspect, carry case belt before transportation. If fallen the carry case due to damage on the belt, it may incur equipment damage or injury.

Always follow safety best practices, including the use of safety goggles and protective clothing when working with fiber optic products, including KF4As.

Do not use the KF4A around high temperatures or flame. Injury or equipment damage may occur.



CAUTION:
HIGH TEMPERATURES



DO NOT SPRAY FREON GAS



CAUTION:
HIGH VOLTAGE

CAUTIONS

Be aware of and avoid hot surfaces associated with thermal strippers and sleeve heaters.
Allow sleeves to cool before handling.

Use the splicer only on a stable surface to avoid falls that may cause damage or injury.

The KF4A should be accurately adjusted and treated in alignment. Do not give it a strong shock.
Use the carrying case provided for transporting and storing the KF4A to reduce humidity, vibration and shock.

When replacing the electrodes:

- Always use UCLSWIFT-approved replacements
 - Ensure correct positioning
 - Always replace in pairs
-

Failure to follow all warnings and cautions to ensure proper function of the KF4A may result in equipment damage or a faulty splice.

Use only ethyl alcohol (96% or higher) or other approved cleaning solutions to clean the lens, V-groove, LCD monitor and main body.

Use the splicer only within the stated operating environmental ranges. Store in a controlled environment to avoid long-term exposure to damaging temperatures and humidity levels.

The KF4A should receive regular service by a UCLSWIFT-authorized service technician to ensure long-term functionality and safety.

2. Product specifications and component

2.1 Product specifications

ITEM	DESCRIPTION
Fiber alignment	Active Clad Alignment
Applicable fibers	SM(G.652), MM(G.651), DS(G.653), NZDS(G.655), SM(G.657 A1, A2/B2, B3)
Fiber count	Single fiber
Applicable fiber dimensions	Cladding diameter: 125 μm , Coating diameter: 150 μm ~3mm
Fiber cleave length	7mm to 16mm
Splicing modes	Splice mode: 300, Heat mode: 100
Average splice Loss	SM: 0.03dB, MM: 0.01dB, DS:0.05dB, NZDS: 0.05dB
Return loss	> 60dB
Splicing time	Typical 7 sec with SM
Splice loss estimate	Available
Sleeve heating time	Typical 13 sec with IS-60 mode, IS-60 sleeve
Applicable protection sleeve	60mm, 40mm and micro sleeves
Storage of splice result	Data : Up to 5,000ea, Image : Up to 5,000ea
Tension test	1.96N to 2.25N
Operating conditions	Altitude: 0~5,000m above sea level, Temperature: -10°C~50°C, Humidity: 0~95%, Wind: 15m/s, non-condensing, dust proof, water proof, shock proof
Storage conditions	Temperature: -40°C~80°C, Humidity: 0~95%
Dimensions	132(W) x 212(L) x 73(H)mm (Without rubber protector)
Weight	1.5kg (Including battery)
Viewing method and display	Two CMOS cameras and 3.5-inch color LCD monitor
Fiber view and magnification	X/Y : 110X, Max :220X
Power supply	Li-ion Battery (DC 14.8V, 3400mAh), 100 ~ 240V AC Charger
Battery life with heat-shrink	Typical 200 cycles
Terminals	USB
Electrode life	Up to 38,000 splices (Lifetime may vary depending on operating conditions)
Cleaver	CF-07FT

2.2 Product package

2.2.1 Standard package











ITEM	MODEL NAME	QUANTITY
Arc fusion splicer	SWIFT KF4A	1
User guide CD	-	1
Cooling tray	CT-01 (40mm)	1
Transporting case	HC-11(Hard Case)	1
Battery	KF-3400	1
AC Charger	FT17015000	1
Wrench	LD-3300	1
USB cable	-	1

2.2.2 Optional package

ITEM	MODEL NAME
Battery	KF-3400
Cleaver blade	BI-07
Electrode	EI-24
External power	DC 12V available for car cigar jack
Sleeve	S09-C, S09, S30-C, S30
Sleeve clamp	SC-01
Optical fiber holder	"HS-250, HS-900, HS-2.5F, HS-IN, LS-900(Loose tube), HF4-SC/FC, HF4-ST, HF4-ILC(choose one)"
SOC connector	SC, LC, FC, ST (refer to FTTx solution catalogue)
Transporting case	ILST-SS03 (L) (soft case)
Work belt	WB-01
Manual stripper	CF-02
Optical module (KF4A+)	Optical Power Module (Optical power meter + VFL)

3. Product outline

3.1 Function buttons

BUTTON	DESCRIPTION
	Press and hold about 1 second to turn the power ON/OFF. Press and hold about 1 second when power is on and splicer turns off.
	Move the cursor to the left. Move fiber on manual mode and adjusts camera's focus. It loads stripping popup menu.
	Move the cursor to the right Move fiber on manual mode and adjusts camera's focus. It loads VFL (Shortcut)
	Move the cursor upwards. It selects each motor on manual mode. It loads splice popup menu.
	Move the cursor downwards It selects each motor on manual mode. It loads heater popup menu.
	Initialize the splice function. It goes back to the menu screen.
	Complete a selection It goes to the next step on the menu screen.
	Splice execution.
	It goes back to the initial screen. It initializes splice function.
	Turn on the stripper. When it is ON, the lamp on the left is in red. Press once more when it is ON and the heater is turned off.
	Turn on the heater. When it is ON, the lamp on the left is in red. Press once more when it is ON and the heater is turned off.

3.2 Component name

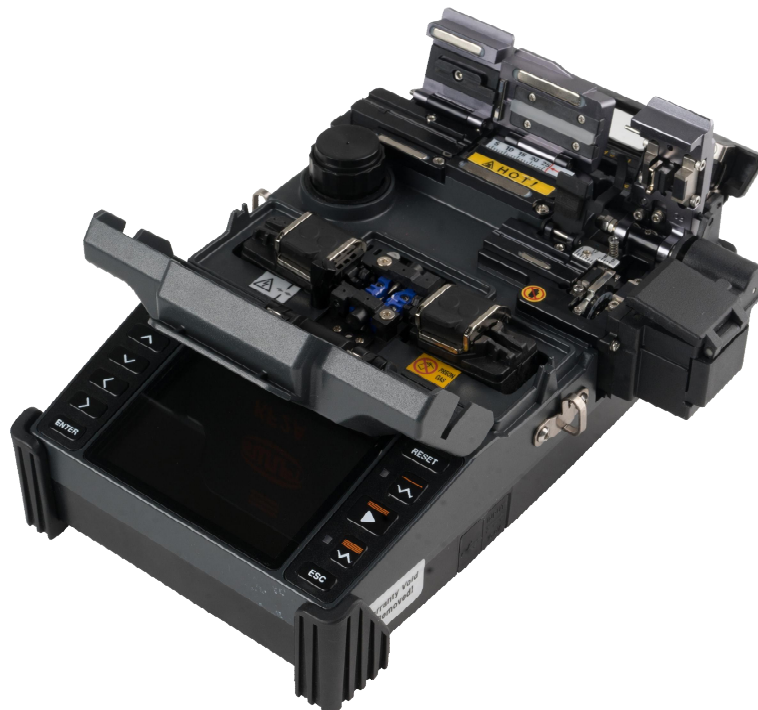
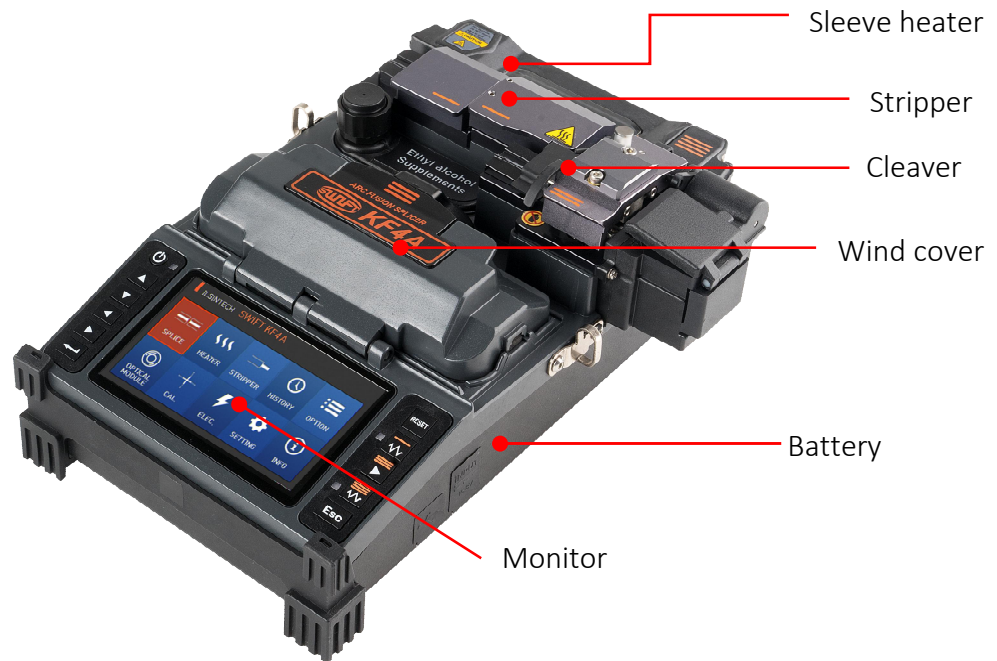



Remaining battery indicator (KF4A+)

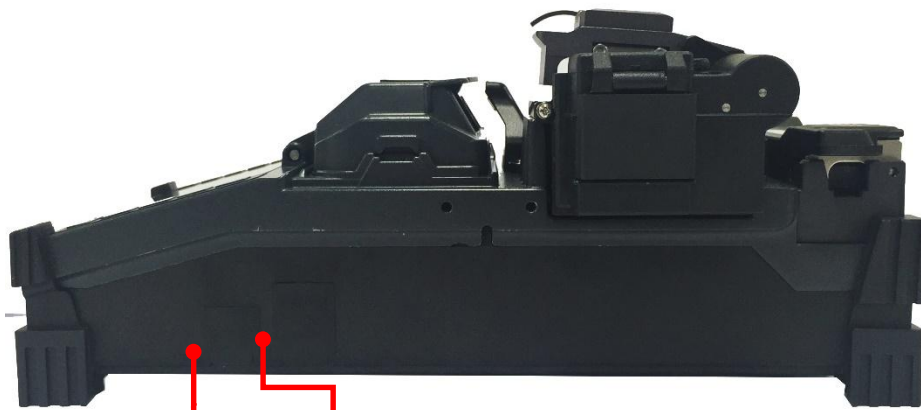

USB

DC OUT

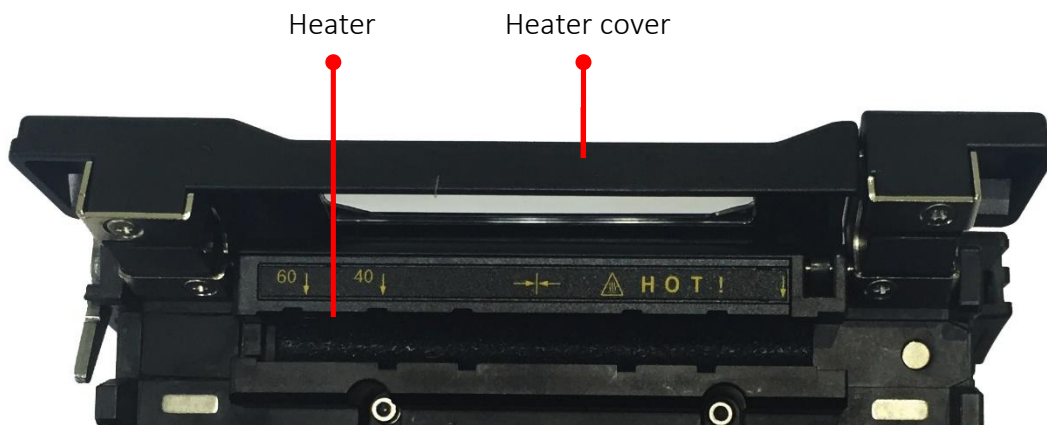

Heater

Heater cover

4. Instructions for use

The following is the initial screen of Swift KF4A. For accurate splice result, splice mode, stripper mode and heater mode should be properly selected. Basic information on Swift KF4A is displayed on the initial screen. Check whether the proper mode is selected before splice.

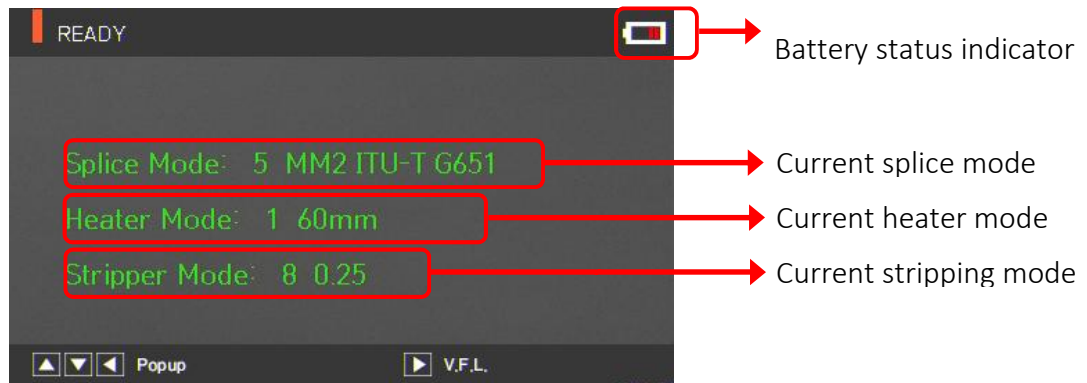

4.1 Power supply

Battery pack is built in at the battery chamber. Loosen the bolts at the bottom cover and exchange battery. Please be cautious when you detach the battery from the chamber.

4.1.1 Built in battery



4.1.2 Battery charging

Make sure you check the voltage, frequency and then the DC cable of AC/DC charger connects to the DC jack of the battery before charging the battery

When the battery is fully charged, LED will turn green and power is disconnected, activating protection circuit to avoid overcharge. The power is turned back on as the battery needs to be charged and charging resumes when the DC cable of charger is connected to the DC jack of the battery.



4.2 How to turn the power ON/OFF

To turn on the power of Swift KF4A, press  and hold about 1 second with the wind cover closed. After the entire functions including motors are initialized, the initial screen is subsequently displayed as follows. For accurate splice, splice mode and heater mode should be properly selected. Current splice mode, stripper mode and heater mode are displayed at the bottom of the screen.



4.3 Fiber cleaning

Wipe fiber clean with soft cloth or cotton moistened with alcohol. Fine dust on the surface of the fiber may increase loss after splice and incur damage on the fiber after heating.

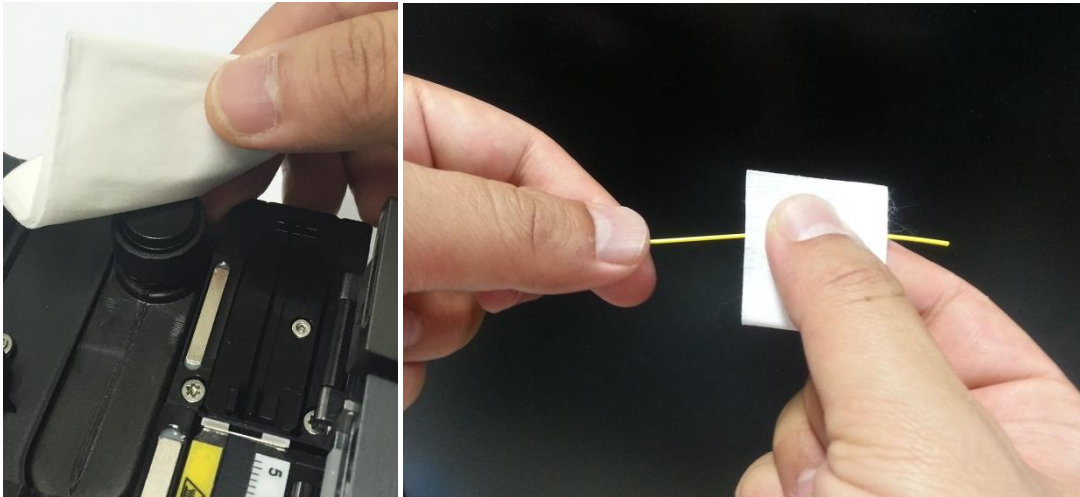

4.4 Inserting fiber to protecting sleeve

Put fiber into the protective sleeve.



4.5 Fiber stripping

Automatic stripper of KF4A automatically performs accurate stripping with single fiber.

This thermal stripper does not incur cracks on stripped fiber with superb tensile force. Stripping length of the fiber can be up to 28.0mm. To keep the equipment's optimal performance, thoroughly understanding and memorizing the instructions is extremely important for proper use.

Also, wipe the fiber clean with soft cloth or cotton moistened with alcohol.

- ⚠ *Be careful not to soak this equipment in any kind of liquid.*
- ⚠ *Keep it clean all the time as it is vulnerable to humidity and dust.*
- ⚠ *Keep and use it at room temperature as deformation can be happened due to high temperatures.*
- ⚠ *Be careful to use the product as a breakdown can be happened due to vibration and shock.*
- ⚠ *When cleaning the product, do not use any organic solvent such as acetone other than alcohol on any of the rubber parts.*

ITEM	DESCRIPTION
Fiber diameter	125 μm
Cable diameter	250 μm , 900 μm
Cleaved length	Max 28.0 mm
Heating time	0 ~ 15 sec
Temperature range	60 °C ~ 150 °C
Tensile force after stripping	4kgf



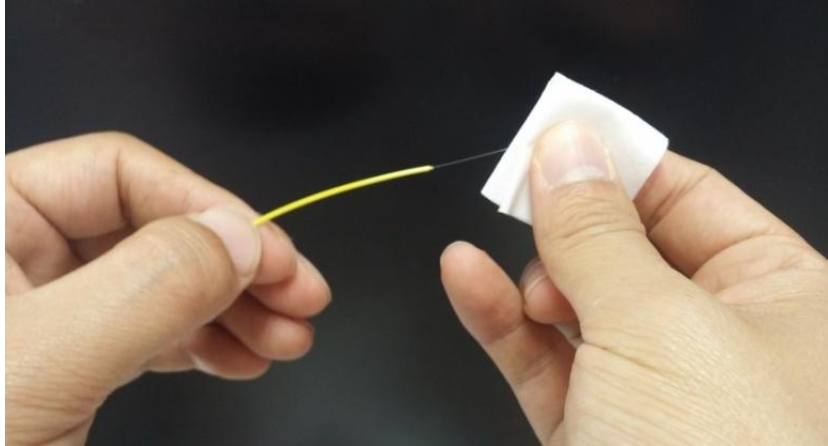

 Use ethyl alcohol with a purity level of 96% or higher.

- i. Heater warms up. Make preparations by opening up the heater cover and slide cover.
- ii. Install fiber to be stripped on the holder as in the figure. The minimum stripping length is 18mm.
- iii. Place the holder with fiber on the holder base and close the cover.
- iv. When the heater cover is closed, the fiber heats up for the preset time period and the slider moves to the left to strip the fiber.
- v. When stripping is completed, open the slide cover and remove the holder. Opening up the heater cover will call back the slider automatically and get ready for the next stripping.
- vi. For the next procedure, remove the stripped sheath residue from the heater and blade parts using a soft brush, etc.
- vii. Handle the blade part with care because it is easy to be contaminated and deformed.

4.5.1 Maintenance

(1) Blade replacement and adjustment

- i. Remove the blade by unscrewing the bolt as shown in the figure when its fails stripping. Removal should be done after moving the slider and it stays to the left position.

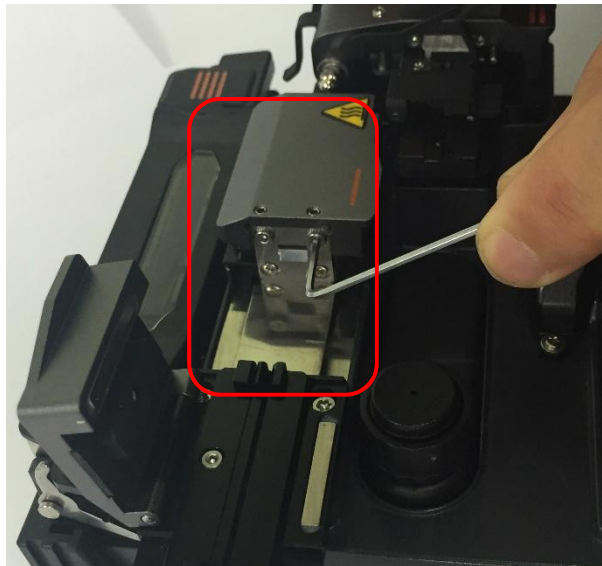

- ii. Assemble a new blade in reverse order of the disassembly process. (composed as 1 pair of each piece both at the top and the bottom)

Setting and stripping can be done properly with no on the both top and bottom.

(2) Product handling and storage

- i. As the main parts (blade, heater etc.) are closely related to the product's life, be careful with its use, during transportation and storage.
- ii. Do not apply excessive force or shock when handling the product.
- iii. Keep the main parts clean at all times of use by using a brush.
- iv. Maintain the product clean at all times.

4.6 Fiber cleaning

The alcohol dispenser of KF4A releases a fixed cleaning agent for fiber cleaning.

- ⚠ *Be careful not to soak this equipment in any amount of liquid*
- ⚠ *Keep it clean at all times as it is vulnerable to humidity and dust.*
- ⚠ *Keep and use it at room temperature as it can become deformed due to high temperature.*
- ⚠ *Be careful when using this product as it may break down due to vibration and shock.*
- ⚠ *When cleaning the product, do not use any organic solvent such as acetone other than alcohol on any of the rubber parts.*

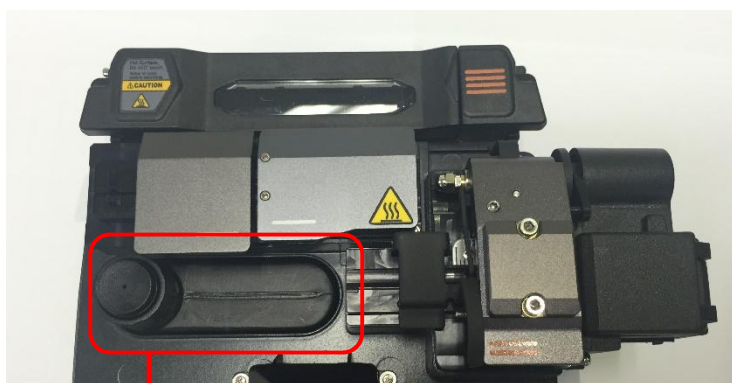

Cleaner



- i. When cleaning, arc the cleaning agent by pressing 2~3 times with cleaning cotton swab. Arc the cleaning agent while covering the entire outlet with cotton to prevent it from spraying outwards.
- ii. When the cleaning agent is no longer pumped, refill it by opening the cap.
- iii. Use MCC-POC03M as the exclusive cleaning agent.

4.7 Fiber cleaving

The automatic cleaver of KF4A cleaves by 90 degree angle cleaving with a single fiber.

Stripping should be in a proper condition.

Fiber alignment in the holder must be in an appropriate condition.

4.7.1 Fiber cleaving

- i. Open the cover and set the holder with the fiber on the holder base and align the stripped fiber straight over the blade, Check the alignment of the fiber.



<Φ250 type>



<Connector type>

- ii. Close body Cover and clamp aligned fiber impregnably.

At this time push cover well in order to rotating blade through gear Pusher



<Φ250 type>



<Connector type>

- iii. Cleave fiber with pushing the cleaving button.

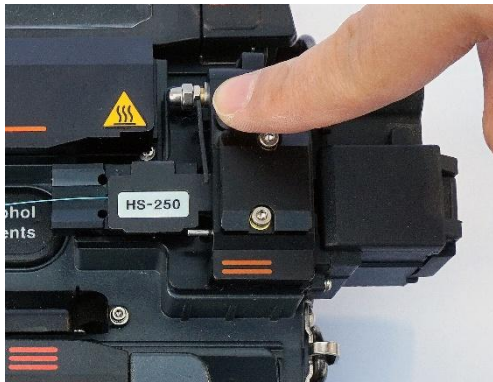

<Φ250 type>

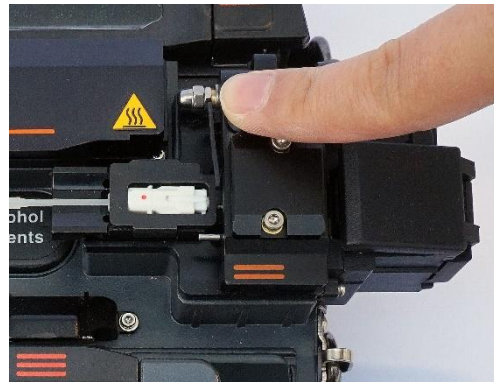

<Connector type>

- iv. Take cleaved fiber from the holder carefully.

Fiber end-face must be careful from dust and debris. The chip of cleaved fiber was collected by automatic chip box

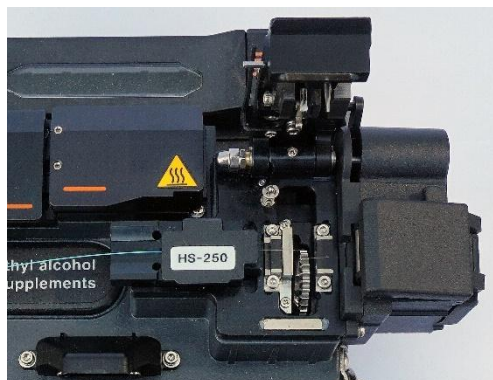

<Φ250 type>

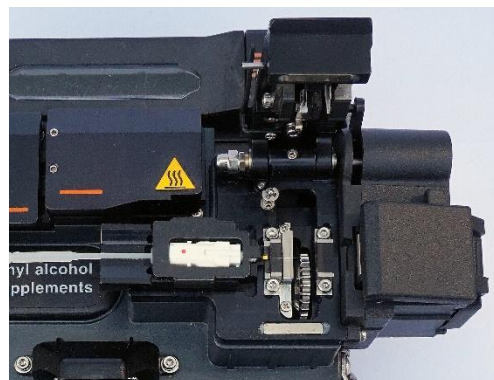

<Connector type>

⚠ For the detailed use of cleaver, refer to the instructions for blade use.

4.7.2 Blade adjustment

- On the blade gear, the channel (cleaving position) from 1 to 24 is marked.
- When it does not cleave the fiber properly , clean the surface of rubber pad with the alcohol-soaked cotton swab (But when clean the rubber pad, do not use acetone or solvent)
- And if cleaver still does not cleave properly, it means the blade is fully used, operators are required to change the cleaving position by the following order
 - i. Remove the cleaver from KF4A main body using a hex wrench as in the figure.



- ii. Then remove the chip box using a hex wrench as in the figure below.

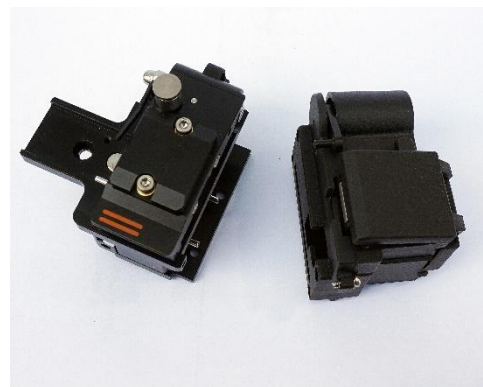
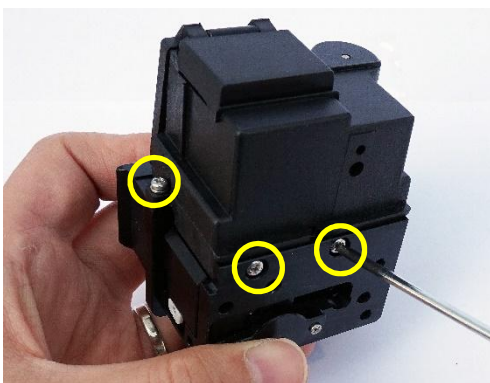

- iii. In order to replace blade, disassemble chip collector assembly and rear pusher. Open the cover as shown picture and press the pusher pin to move slider to forward

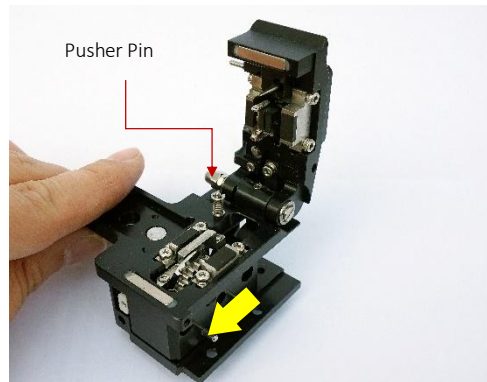

- iv. Remove blade pin completely using (-) driver.
Turn clockwise blade pin left side bolt

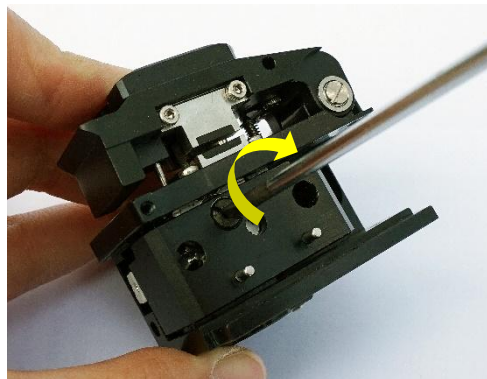

- v. Remove old blade with blade gear from body and replace new blade with blade gear. In here reassembling should be done in a reverse order of disassembling.
At this time, especially be careful not to damage the blade.
Check the blade operating condition with cleaver cover.

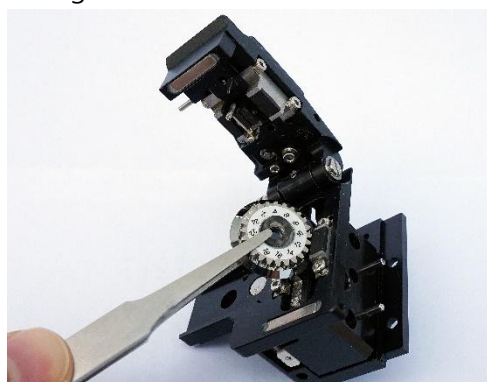

4.7.3 Blade Mode (Rotating/locking) change

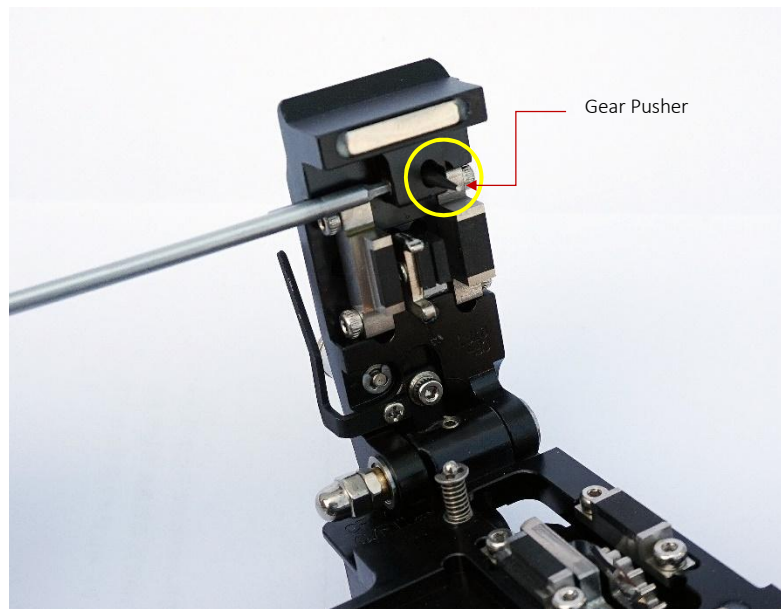

- i. Adjust gear pusher position after loosen Set-screw as shown picture

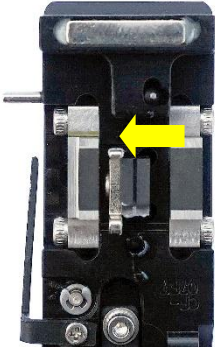
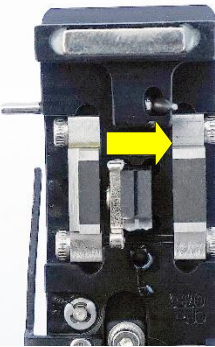
Blade rotating mode	Blade lock mode
	
<p>Initial setting mode will be set as shown picture (Rotation mode)</p>	<p>When the blade is used without rotating</p>

4.8 KF4A Sleeve-Heater

The sleeve heater of KF4A reinforces spliced point of the single fiber.

The quality of fusion splicing on the fiber should be good.

Fiber that sleeve tube is inserted to heater should be properly aligned and installed.

Heater cover should be closed while heater is on.

ITEM	DESCRIPTION
Cable diameter	$\Phi 250 \mu\text{m}$, $\Phi 900 \mu\text{m}$, $\Phi 2.0 \text{ mm} \sim \Phi 3.0 \text{ mm}$
Sleeve length	standard 32 mm
Heating time	20~35 seconds
Temperature range	130°C ~ 200 °C

- i. Choose the heater mode after the confirmation of the length for the sleeve tube when placing a sleeve tube on a heater.
- ii. Place the spliced point in the middle of the sleeve tube first. Then, checking out the heating part on the heater and place the sleeve tube on right position.

 Choosing improper mode of the heater for a sleeve tube may not shrink the sleeve tube properly. Especially, SOC (Splice-On-Connector) should be placed on the right side edge of the heater in order to line up the right end of the sleeve tube to the right side edge of the heater as shown on the picture below (Right picture). If SOC is placed in the middle or on the left side, sleeve tube of the SOC does NOT shrink.



[Optical Fiber]

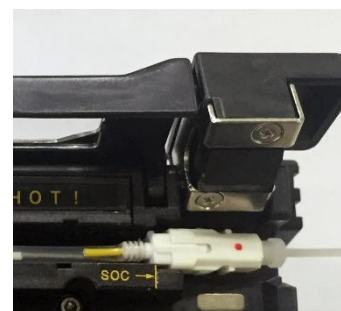

[SoC Connector]

- iii. After settling the fiber, turn on the heater by pressing . (Heating time 20sec)



iv. Remove the sleeve protected fiber by opening the cover when the cooling is completed.

 *The better positioning of the fibers will shorten heating time*

4.9 Splice procedure

The status and cleaved quality of the fiber can be monitored by using an image processing system by Swift KF4A. For better splice result, however, visual inspection is required also.

In auto mode, the splice procedure begins automatically as the wind cover is closed.

- i. Fibers installed on the splicer advance toward each other and stop. The fibers align once cleaning arc is done. After that, the splicer checks cutting the cleaved angle of each fiber, the shape of the end faces, contaminations and so on. When the measured cleaved angle is bigger than the preset value or damage is detected on fiber, error message is displayed on the screen. And splice procedure stops as well. Even if there is no error message displayed, visual inspection on the monitor screen is always recommended.
- ii. Check that the Wind cover is properly closed at more than 900um cable ($\varnothing 2.0 \sim \varnothing 3.0 \text{um}$)
- iii. Fibers are aligned cladding to cladding after inspection. Deviation on clad axis can be displayed on screen.
- iv. After alignment completes, arcing is conducted to splice fibers.
- v. After splicing is completed, the estimated value of loss is displayed on the screen. The estimated value of splice loss is subject to various factors related to error. These factors related to an error affect the estimation and calculation of estimated loss value as well. Calculation of estimated loss is based on factors such as MFD. When estimated loss value exceeds the preset value and error message is displayed on the screen. The error message is also displayed when the spliced fibers are too thick or thin or when bubbles are generated on the spliced point. If the splice result shown on the screen is not considered good enough, it is recommended to conduct splicing again
- vi. The splice result is saved as follows.
- vii. When splice completes, splice result is automatically saved.



4.10 Removing the spliced fiber

- i. Open the cover of the sleeve heater.
- ii. Open the wind cover.
- iii. Hold the fiber on the left and open the clamp on the left.
- iv. Open the fiber clamp on the right.
- v. Hold both sides of spliced fiber and separate the fiber from Swift KF4A with care.

4.11 Heating protection sleeve

- i. Move spliced point to the center of the protecting sleeve. Place the protected pin in the sleeve with face down.
- ii. Place the protecting sleeve at the center of sleeve heater.
- iii. Hold and put down the both fibers as shown in the figure then the heater cover will automatically close.
- iv. Heating starts by pressing .
- v. LED is turned off when heating is completed.
- vi. Open the heater cover and take out the fiber. Do not touch the protecting sleeve or heater at any point during or right after heating.
- vii. Conduct a final inspection on whether there are bubbles, fragments or any dust on the sleeve.



4.12 Use of Work Belt

The work belt of Swift KF4A is a type of auxiliary equipment that combines with its main body to facilitate working at a manhole, utility pole, etc.

4.12.1 Use of Work Belt



Work belt components



5. Maintenance of splice quality

5.1 Cleaning and Inspection before splice

5.1.1 V-Groove cleaning

When the inside of V-Groove is contaminated, splice quality may deteriorate. Thus, it is important to regularly inspect and frequently clean the V-Groove as follows.

- i. Open the wind cover.
- ii. Clean the V-Groove using a cotton swab moisten by alcohol and any proper cleaning agents. Remove the remaining alcohol from the V-Groove using a clean and lint free dry cotton swab.
- iii. When a foreign substance is not removed with cotton swab, clean it with the tip of a cleaved fiber and then repeat the step above.

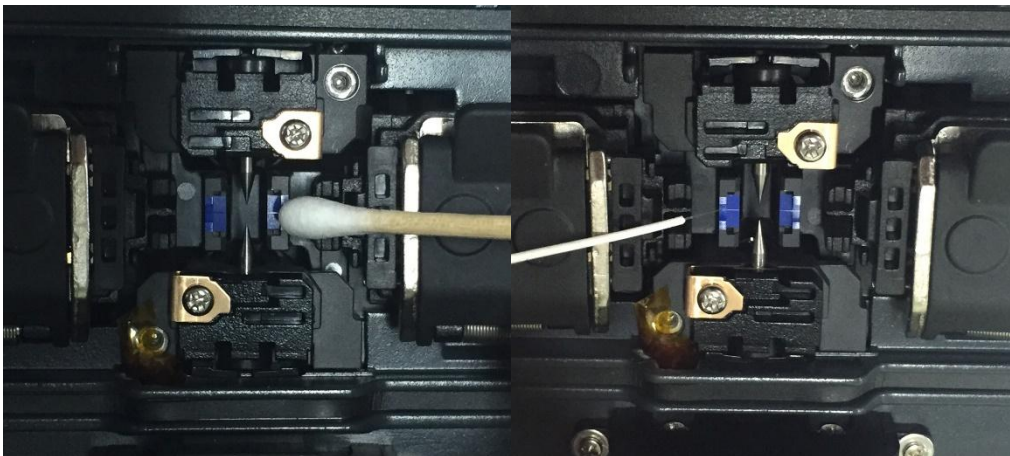

5.1.2 Pusher Block cleaning

Pusher Block contamination incurs poor splice quality due to irregular pressure apply to the fibers. Thus, it is important to frequently inspect and regularly clean it.



5.1.3 Cleaver cleaning

If the cleaver's blade and rubber pads are contaminated, the cleaving quality may deteriorate. In turn, the splice loss rate can be consequently increased. Thus, clean the cleaver blade and rubber pad frequently using a cotton swab moisten by alcohol. This is critical to keep the cleaved quality of the fiber. (Do not use acetone or solvent when cleaning the rubber pad.)

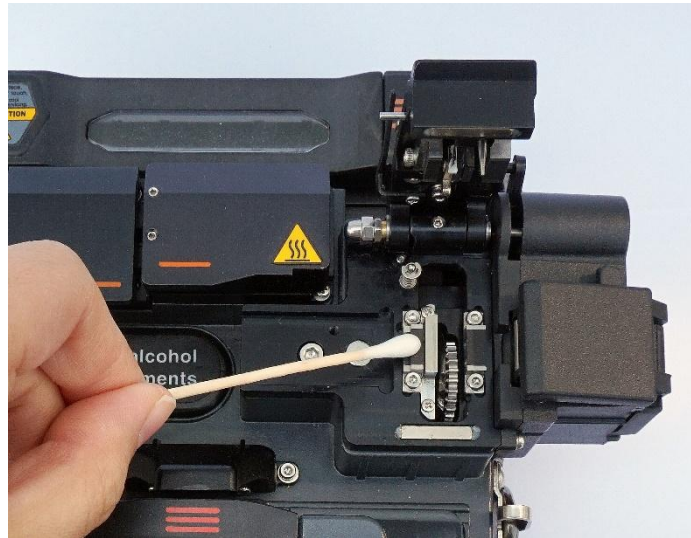

5.2 Regular inspection and cleaning

To ensure splicing quality, regular inspection and cleaning is required.

5.2.1 Object lens cleaning

Contamination on object lens' surface disturbs the identification of fiber core location and consequently incurs high splice loss. Thus, 2 object lenses should be kept clean at all times. If accumulated dust stays for a prolonged period, it may be difficult to remove. Therefore, clean the lens frequently as follows.

- i. Turn the power off before cleaning the object lens.
- ii. Separate the Electrodes.
- iii. Clean it using a soft cotton swab moisten with alcohol in circular motion from the center as in the figure below. Dry out alcohol remaining on object lens' surface using a clean, lint free dry cotton swab

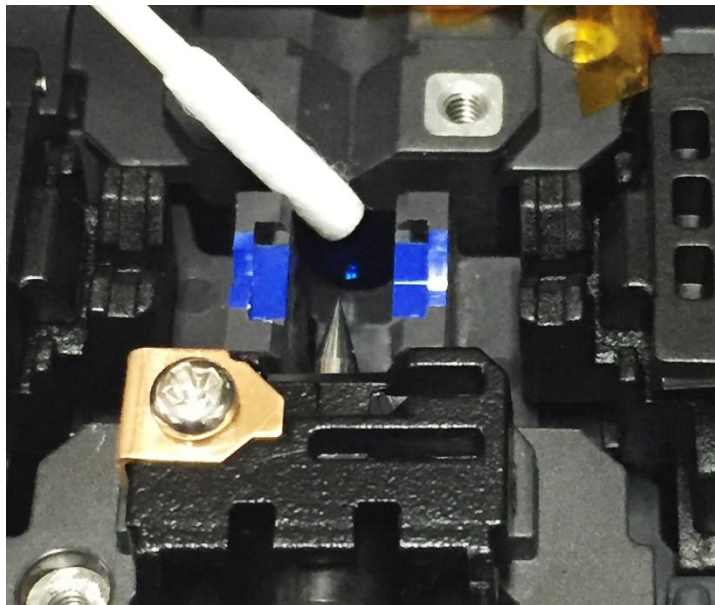

- iv. Surface of object lens should be clean without any line or stain.
- v. Reassemble the Electrodes.
- vi. Turn the power on; check whether there is any line or stain on the monitor and; conduct a self-diagnosis.

5.2.2 Electrodes replacement

It is recommended to replace the electrodes after using appx 4,000 times. If the number of arc exceeds the replacing cycle, a message for electrodes replacement is displayed on the screen. Without electrodes replaced splice loss increases and the tensile force at the splicing point weakens.

- i. Turn the power off when replacing the electrodes.
- ii. Open the wind cover and unscrew the clamp screw of the electrodes block.

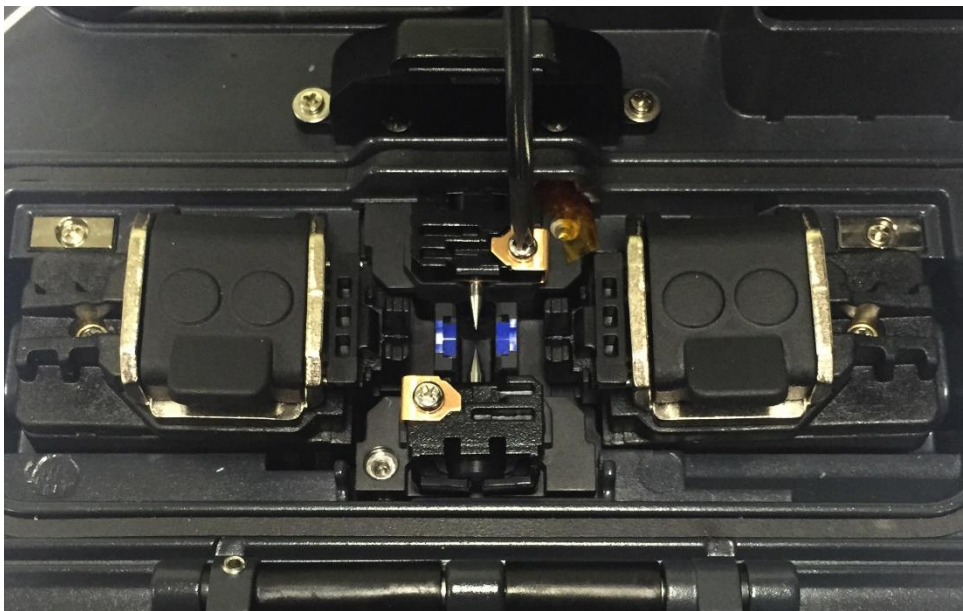



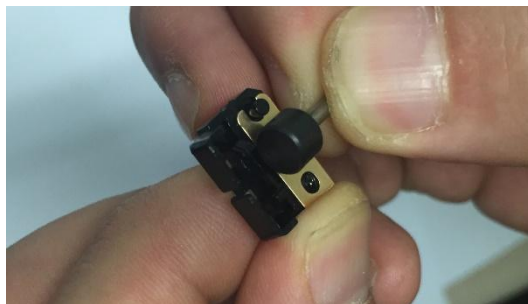



- iii. Remove the electrodes block and the electrodes.



- iv. Clean the electrodes carefully by using a soft cotton swab moisten by alcohol, then install it.
- v. Turn the power on and conduct electrodes stabilization process in the menu.

6. Menu

The main menu has 10 submenus. Press  to load main menu. The 10 submenus can be selected by using     and  or by directly pressing the screen. The main menu screen is as follows.



■ SPLICING

- Replace: Selects and replaces a certain splice mode within the database
- Add: Selects and adds a certain splice mode within the database
- Select: Selects a splice mode to run
- Edit: Edits set values of splice mode
- Cancel: Closes the menu window
- Delete: Deletes splice mode

■ HEATER

- Replace: Selects and replaces a certain heater mode within the database
- Add: Selects and adds a certain heater mode within the database
- Select: Selects a heater mode to run
- Edit: Edits set values of heater mode
- Cancel: Closes the menu window
- Delete: Deletes heater mode

■ STRIPPER

- Delete: Deletes stripper mode.
- Replace: Selects and replaces a certain stripper mode within the database.
- Add: Selects and adds a certain stripper mode within the database.
- Edit: Edits set values of for the stripper mode.

■ HISTORY (Splice results)

- DISPLAY HISTORY: Displays splice result and image
- CLEAR HISTORY: Deletes all data

■ OPTION

- DEFAULT: Auto, pause, auto heater
- MENU LOCK: Menu lock setting
- PASSWORD: Password sets upon locking

■ OPTICAL MODULE

- Optical Power Meter: Checks up optical power meter information
- V.F.L.: Activate visual fault locator.

■ CALIBRATION (CAL .)

- ARC CALIBRATION: Adjusts arc calibration intensity
- ARC TEST: Check arc quantity through arc test
- DIAGNOSTIC TEST: Diagnoses equipment state
- MOTOR DRIVE: Operates motor manually
- MOTOR CALIBRATION: Initializes motor speed and location

■ ELECTRODE

- ELECTRODE STABILIZE: Conducts stabilization of electrodes
- ELECTRODES CAUTION: Sets the number of uses to inform about electrode replacement
- ELECTRODES REPLACE: Explains how to replace the electrodes
- ELECTRODE USED: Displays the electrode-use count

■ SETTING

- LANGUAGE: Selects a language
- DATE: Sets the present time
- POWER SAVE: Sets sleep mode
- VOLUME: Adjusts the intensity of the buzzer sound
- LCD BRIGHTNESS: Adjusts screen brightness

■ INFORMATION

- MAINTENANCE INFO: Displays maintenance schedule
- SENSOR VALUE: Indicates temperature and pressure
- VERSION: Shows the current version of the product
- HELP: Consists of:
 - NAME OF PARTS
 - CLEAN AND INSPECT
 - WARNINGS
 - A/S CONTACT LIST

Popup Menu

The purpose of the popup menu is to facilitate easy and quick access to the splice mode and heater mode. User can access the popup menu in various ways.

[Displaying popup menu]

- i. Splice popup menu can be displayed the current splice mode by pressing  on initial screen.

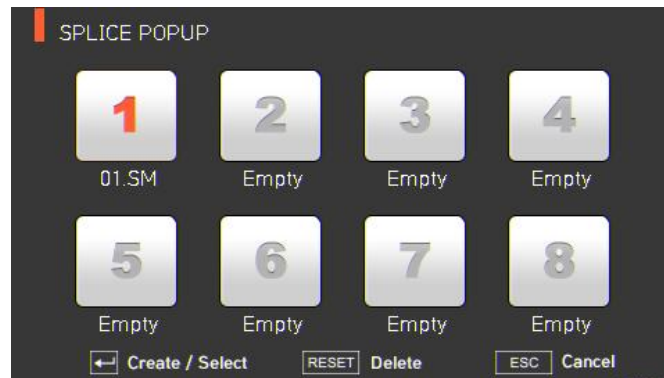

- ii. Heater popup menu can be displayed the current heater mode by pressing  on initial screen.



- iii. Stripper popup menu can be displayed the current stripper mode by pressing  on initial screen.



[Splice popup menu]

- Adding splice mode

- Display splice popup menu by pressing  on initial screen.

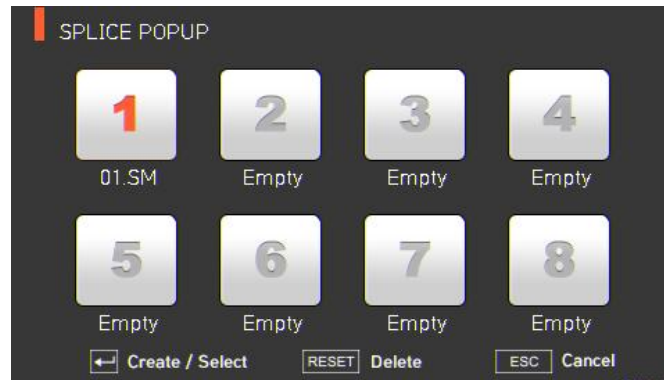

- Select an empty slot by pressing     and then press .



- Select a splice mode to add up to the empty slot.

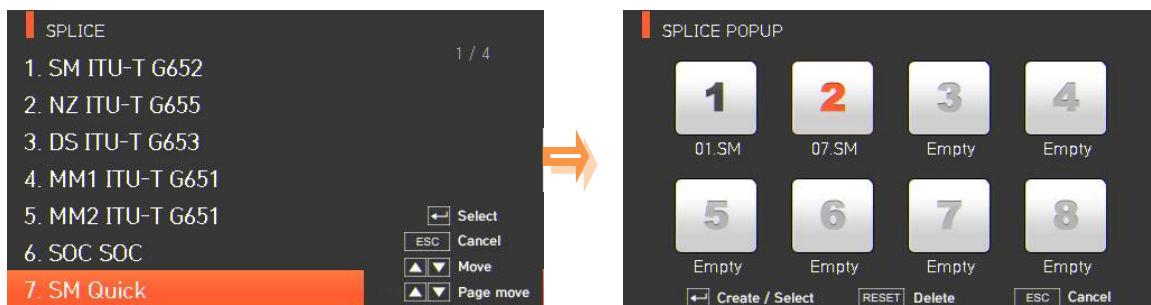

- Deleting splice mode

i. Select a mode to be deleted.



ii. Delete it by pressing



[Heater popup menu]

- Adding heater mode

i. Display heater popup menu by pressing  on initial screen.

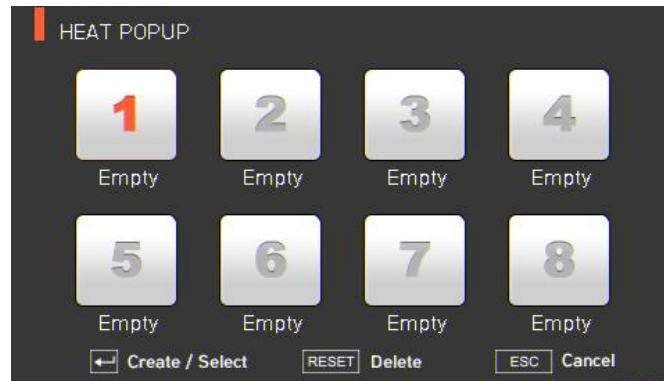

ii. Select an empty slot by pressing     and then press .

iii. Select a heater mode to add up to the empty slot.

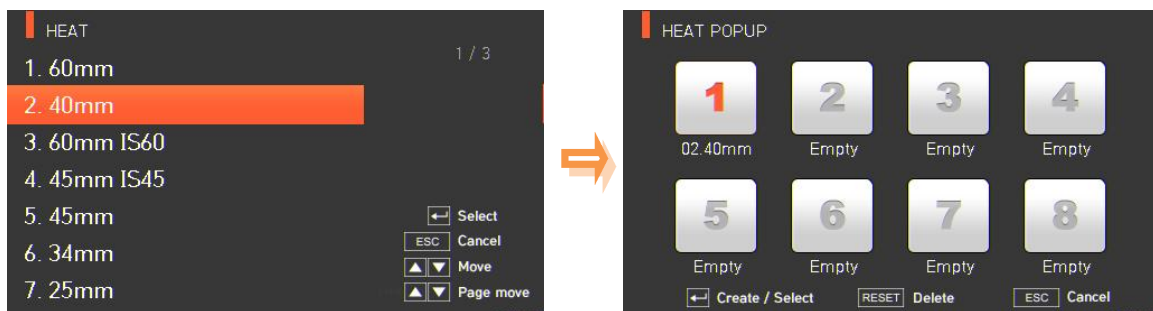

■ Deleting heater mode

- i. Select a mode to be deleted.



- ii. Delete it by pressing

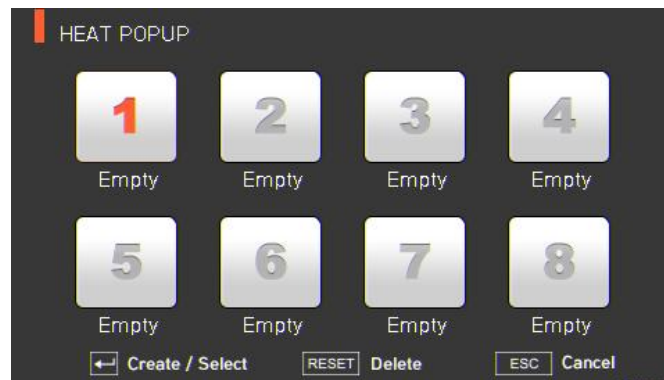

[Stripping popup menu]

- Adding stripper mode

i. Display stripping popup menu by pressing  on initial screen.

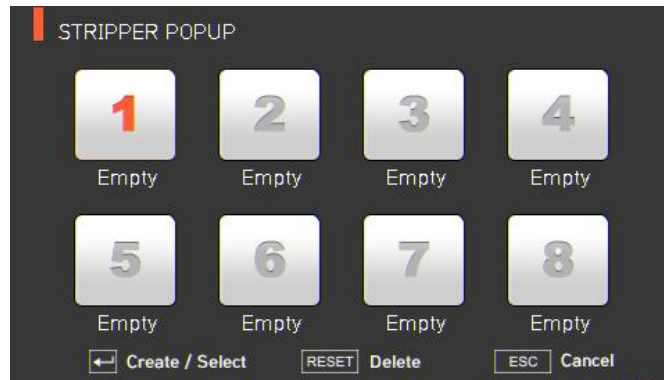

ii. Select an empty slot by pressing     and then press .



iii. Select a stripper mode to add up to the empty slot.

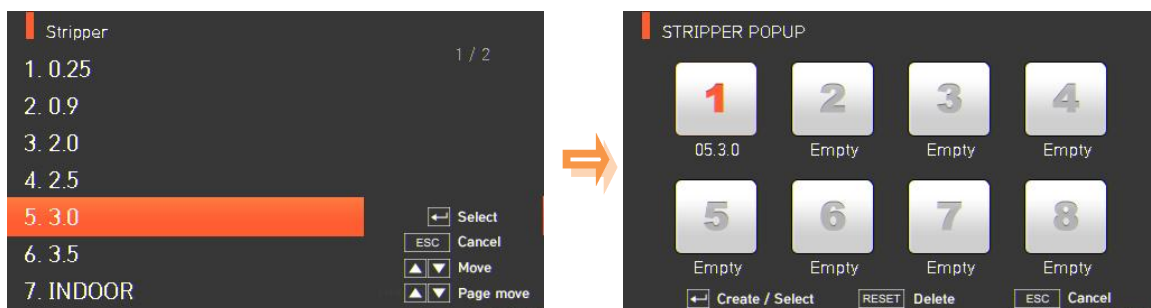

■ Deleting stripper mode

- i. Select a mode to be deleted.

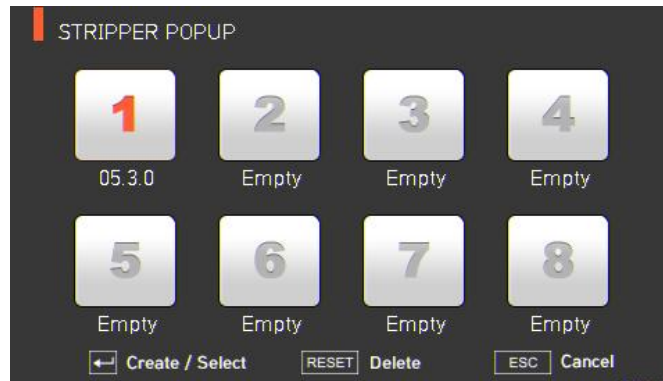

- iii. Delete it by pressing

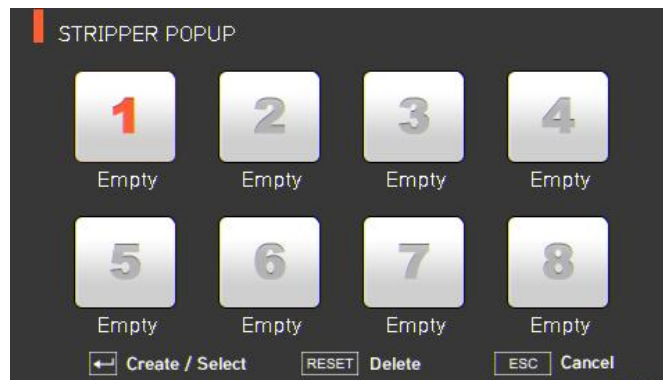

6.1 Splice

To display splice mode, press and select “Splice” menu with button. It displays a screen to select splice mode as follows. The screen has a list of splice modes to facilitate a user’s easy selection and use of splice mode. In addition, splice mode can be expanded and saved up to 300 modes. These splice modes are classified into general mode and user-defined mode.

- General splice mode: No. 1~26
- User-defined splice mode: No. 27~300



[Splice modes summary]

SPLICE MODE	DESCRIPTION
SM	For basic SM fiber. MFD of single mode fiber is about 9~10 μm at 1310 nm wavelength.
NZ	For NZDS fiber. MFD of NZDS fiber is about 9~10 μm at 1550 nm wavelength. WDM fiber can also be spliced on this mode.
DS	For DS fiber. MFD of DS fiber is about 7~9 μm at 1550 nm wavelength.
MM	For MM fiber. The core diameter of MM fiber is about 50~62.5 μm.
Other	Other splice modes are saved in the KF4 database. New splice modes are currently being updated. Users should upgrade equipment regularly by contacting UCLSWIFT.

6.1.1 Deletion

First, select a splice mode by pressing . And then press and the selected mode is deleted. General modes no. 1~26 are unable to be deleted.

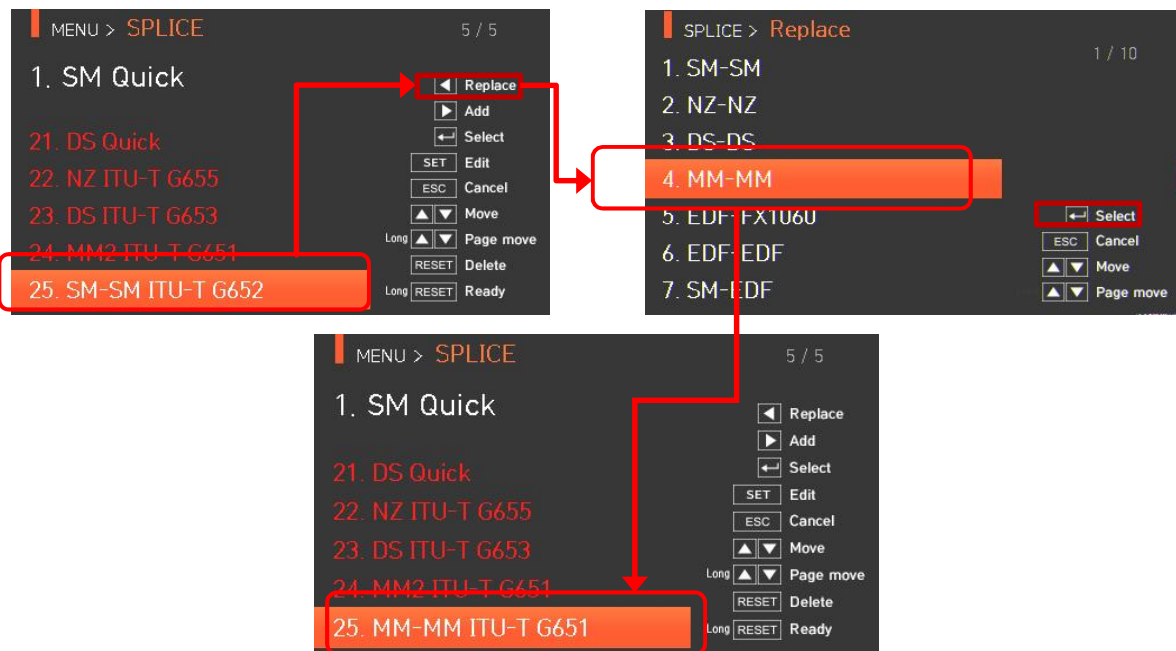

6.1.2 Replacement

Select a splice mode to replace and press , and splice modes saved on the database are displayed on the screen. Select a splice mode to replace and press , and the mode is replaced with the new mode.



Preset modes Nos. 1~26 cannot be replaced.

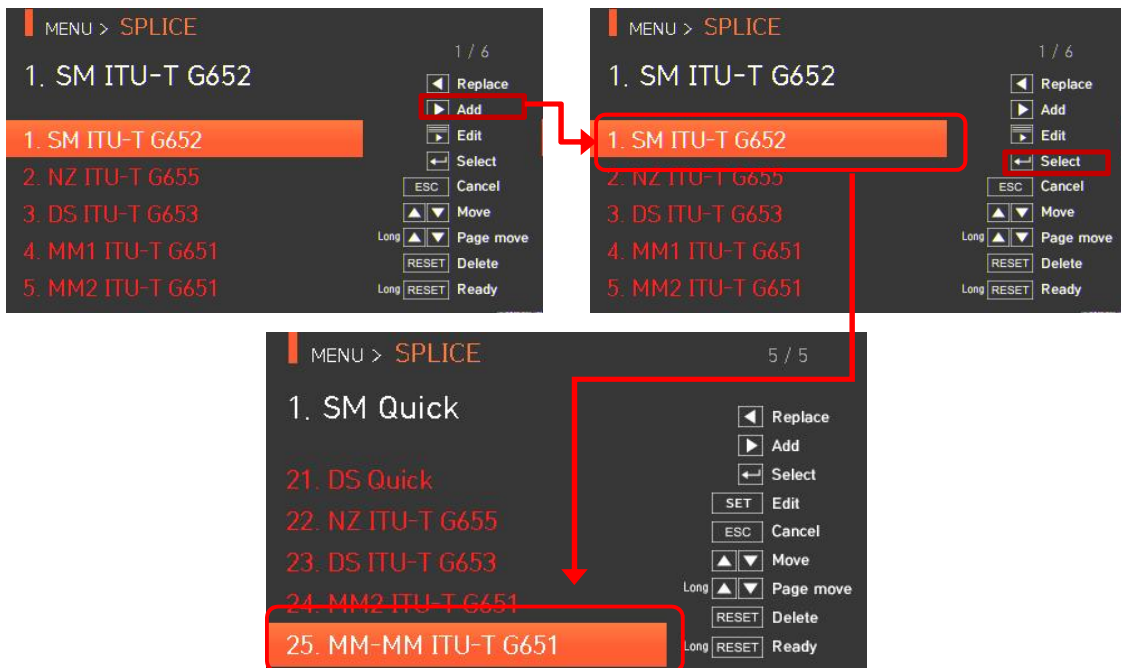

6.1.3 Addition

Press  and splice modes saved on the database are displayed on the screen. Select a splice mode to add and press , and the mode is added. The newly added mode is located on the last number.



Additions cannot be made on general modes Nos. 1~26.

6.1.4 Editing splice modes

Select a splice mode to edit with  and press  then different set values of the selected splice mode are displayed. Press a set value and change it into the proper one.

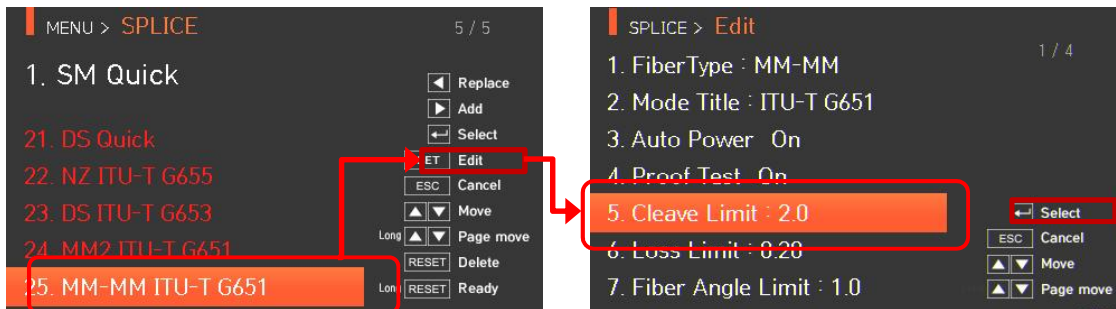

[Set values editable within mode]

SET VALUE	DESCRIPTION	GENERAL MODE	USER MODE
Fiber Type	Displays the list of splice mode that is saved on the splicer data to facilitate the selection of a proper mode for use. Among splice modes saved on the database, it copies a similar splice mode to use an editing function.	Editable	Editable
Mode Title	Mode title 1 is for indicating splice mode within 11 characters at a maximum.		
Auto Power	The closer fibers are aligned to the core center with a fewer number of errors, the quicker and better the arcing is done.	Uneditable	
Proof Test	Conducts tensile force test after splice.		
Cleaved Limit	Sets the cleaved angle's error limit.	Editable	
	When either of the cleaving angles on both fibers are outside the limit., an error message is displayed.		
Loss Limit	Sets the estimated loss value's error limit.		
	When estimated loss is higher than the limit, error message is displayed.		
Fiber Angle Limit	When the bending of 2 spliced fibers exceeds the set limit, an error message is displayed.	Uneditable	
Cleaning Power	A short arc cleaning is conducted to remove fine dust on the fiber surface upon initial stage of fiber alignment. It sets the intensity of the cleaning arc.	Editable	
Cleaning Time	It sets the time for the cleaning arc.	Editable	
Gap	Upon final alignment, it sets the clearance of the cross section between both fibers.	Uneditable	
Gap set Pos	It sets location of fiber spliced at the center of arc.		
		When MFD of both fibers differs, do the sealing procedure by melting the smaller MFD fiber more than the bigger MFD fiber. To heat the smaller MFD fiber more, splice loss can be lowered by	

	moving the clearance location toward the bigger MFD fiber at the center of arc.		
Prefuse Power	It sets initial arc amount from the beginning of arc before the fiber is advanced. If the value of initial arc amount is too low, the angle of the fiber cross section is poor and consequently, an offset can be incurred on the axis if it is too high, the fiber can be made round or burnt too much and, consequently, the splice loss value can be big.		
Prefuse time	It sets the initial time from the beginning of the arc before the fiber advance. If [Prefuse time] is long, it means the same that [initial arc amount] gets big.		
Overlap	It sets the duplication of the fiber on for the fiber advance amount. If [Prefuse Power] is weak or [Prefuse time] is short, set the [overlap] to somewhat small and if the arc amount is strong and the time is long, set it to somewhat big.		
Arc1 Power	Main arc can be adjusted by 2 levels. The first level of arc is [Arc1 Power] and the second is [Arc2 Power]. [Arc1 Power] is set in this area.		
Arc1 Time	It sets the time for [Arc1 Power].		
Arc2 Power	[Arc2 Power] is the second level of arc. [Arc2 Power] is set in this area.		
Arc2 Time	It sets the time for [Arc2 Power].	Uneditable	Editable
	It sets the time for [Arc2 Power]. [Arc time 2] is generally set as "OFF." It can set the arc time as a very long time period but when [Arc1 Time] and [Arc2 Time] exceed 30 seconds, the electrodes can be damaged.		

Arc2 On - Time	While [Arc2 Power] is on arc, you can set the arc amount as “ON” and “OFF” in turn. The time period for [Arc2 Power] being “On” is set in this area. For re-arc, set the arc time as “ON” at all times.		
Arc2 Off - Time	It sets the time period for the arc of [Arc2 Power] when it is turned off. When [Arc2 Power] is occasionally stopped, re-arc can also be stopped. When re-arc is continuously required, set as to “OFF.”		
Rearc Time	It sets re-arc time.	Editable	
	Within [splice mode edition], it automatically sets to arc the re-arc amount with the same intensity as that of [Arc2 Power]. If [Arc2 Power] is set as ON/OFF, re-arc is automatically changed.		
Taper Splice Off	When the fiber is made thin, the splice loss is sometimes increased. This pulling function is set to “OFF.” The following 3 parameters decide the pulling shape.	Uneditable	
Taper Wait	It designates the time period from the last of the advanced fiber amount to the beginning of pulling.		
Taper Speed	It sets the fiber pulling speed.		
Taper Length	It sets the fiber pulling time.		
Offset	It is the sum of the initially measured splice loss value and the increased loss. When splicing a special fiber or other fibers, high loss may be incurred in spite of optimum arc conditions. To match the estimated splice loss and the actual splice loss, the minimum value of actual splice loss should be set.		

6.1.5 Selection

Press  and the selected splice mode is saved on memory and it is used upon splicing.

6.1.6 Close

Press  and it goes back to the previous stage.

6.2 Heater

To display heater mode, press  and then select “HEATER” from the menu using

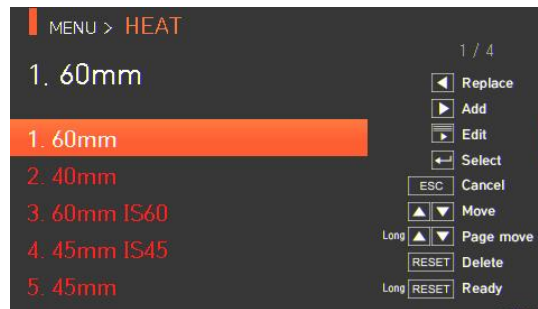

. The selecting screen is equipped with various heater modes to facilitate easy selection. Heater mode can be expanded and saved for up to 100 modes. Heater mode Nos. 1~16 cannot be deleted or replaced.



[Outline of heater mode]

SET VALUE	DESCRIPTION
60mm	Standard 60mm micro sleeve
40mm	Standard 40mm micro sleeve
60mm IS-60	60mm micro sleeve
45mm IS-45	45mm micro sleeve
S09	45mm sleeve for 0.9mm cable
S09-C	22mm sleeve for SOC(SC-0.9mm)
S20	45mm sleeve for 2.0mm cable
S30	45mm sleeve for 3.0mm cable
S30-C	32mm sleeve for SOC(SC-3.0mm)
LC09/20-C	25mm sleeve for SOC(LC-0.9 , 2.0mm)
ST09-C	28mm sleeve for SOC(ST-0.9mm)
ST30-C	36mm sleeve for SOC(ST-3.0mm)

Choose the right mode for each sleeve tube type and SOC. Otherwise sleeve tubes do NOT shrink properly.

-  For the SOC, operators must use UCLSWIFT standard products. For other sleeves, see manufacturer specifications and adjust manually.
-  Heater modes specify temperature, time and heating location on the heater plate.

6.2.1 Deletion

First, select a heater mode by pressing . Press to delete.

Mode Nos. 1~16 cannot be deleted.

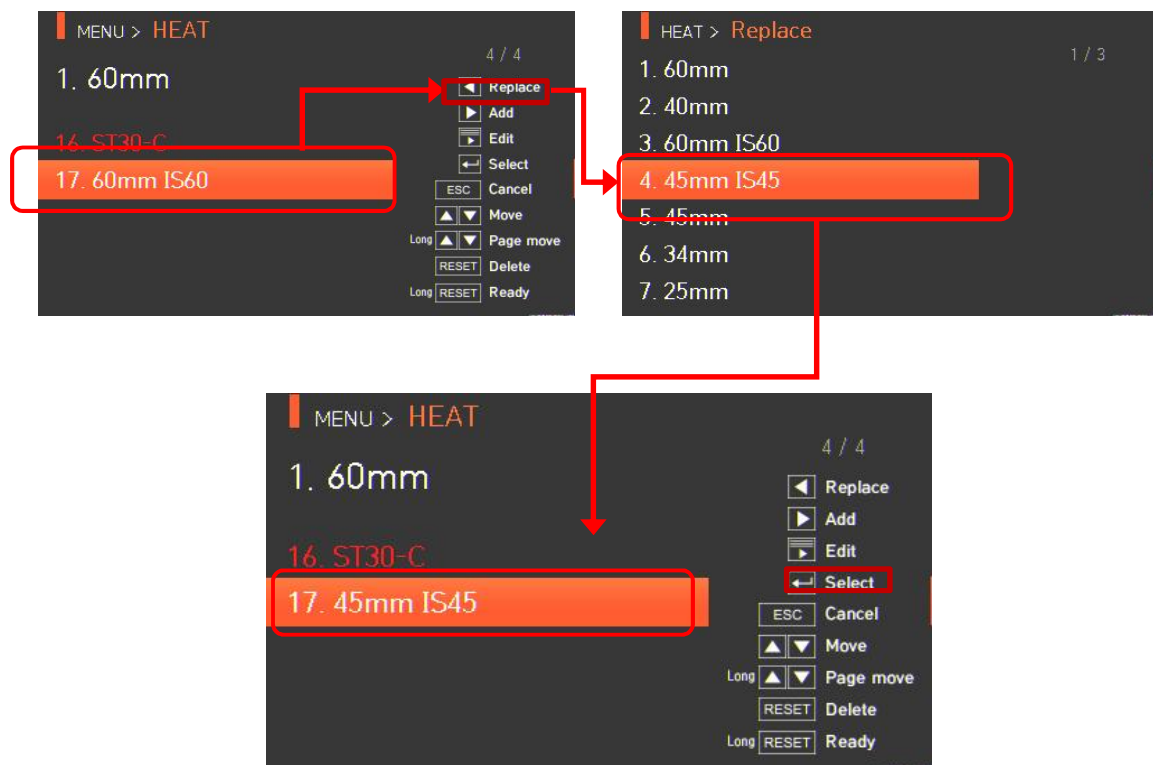

6.2.2 Replacement

Select a heater mode to replace, and press to display heater modes on the screen. Select desired heater mode and press to replace with the selected mode.



General modes Nos. 1~16 cannot be replaced.

6.2.3 Addition

Press  to display heater modes on the screen. Select a heater mode to add and press  to add. The newly added mode is located on the last number.

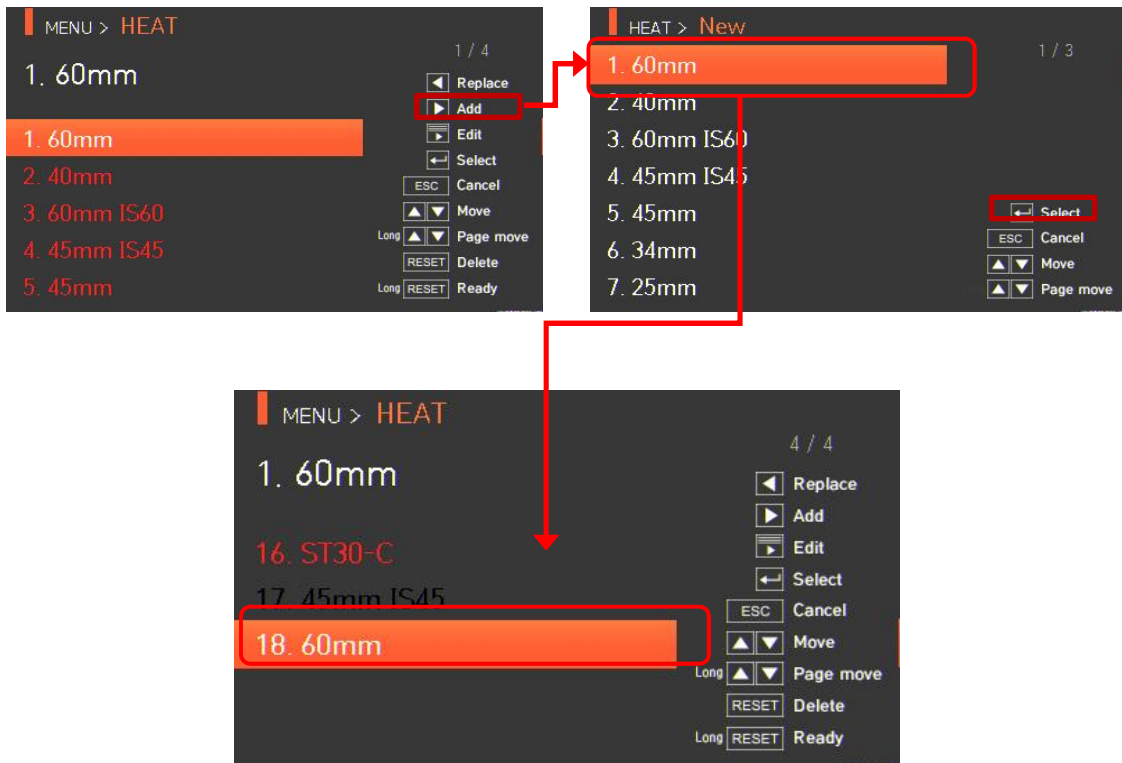

Additions cannot be made on general modes Nos. 1~16.

6.2.4 Edition

Select a heater mode to edit with and press Values of the selected heater mode are displayed. Press a set value to change.

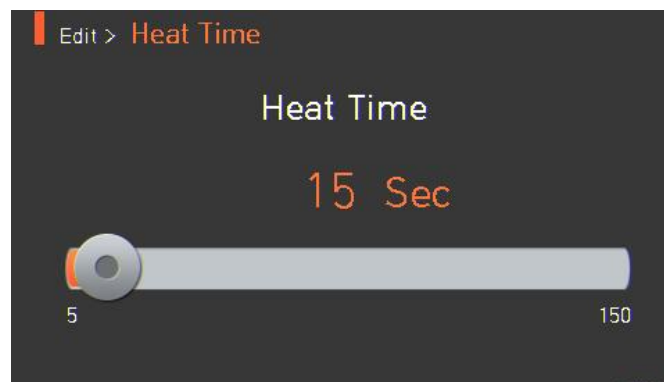



6.2.5 Selection

Press to save the selected heater mode to memory and it is used upon operating the heater.

6.2.6 Close

Press to return to the previous stage.

6.3 Stripper

To display the stripper mode, press  and then select “stripper” menu with  button. It displays a screen to select the stripper mode as follows. The selecting screen is equipped with various stripper modes to facilitate the user’s easy selection and use of the stripper mode. In addition, stripper mode can be expanded and saved for up to 100 modes. Stripper mode no. 1~7 cannot be deleted or replaced either.

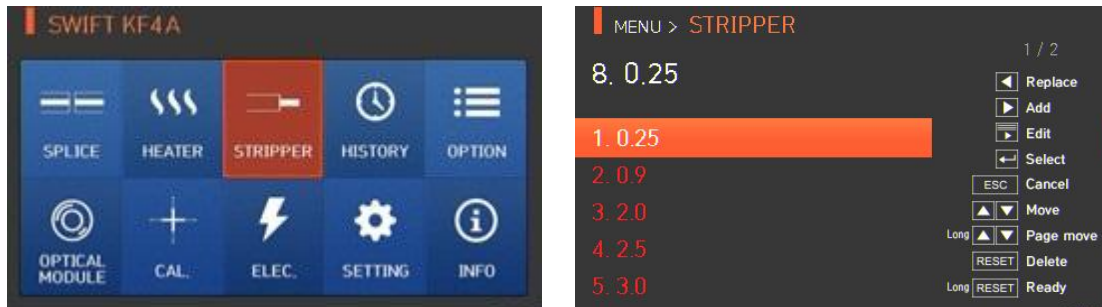

[Outline of stripper mode]

SET VALUE	DESCRIPTION
Modes	<p>Matching the sorts of fiber</p> <p>All stripping lists are displayed.</p> <p>The user may copy or chose program mode that is required or desired.</p>
Stripping time	As the stripping time can be selected between 0sec ~ 15.0sec, select the proper one for fiber sheath.
Stripping temperature	Set stripping temperature.

6.3.1 Deletion

First, select a stripper mode by pressing . Press to delete. Mode Nos. 1~7 cannot be deleted.

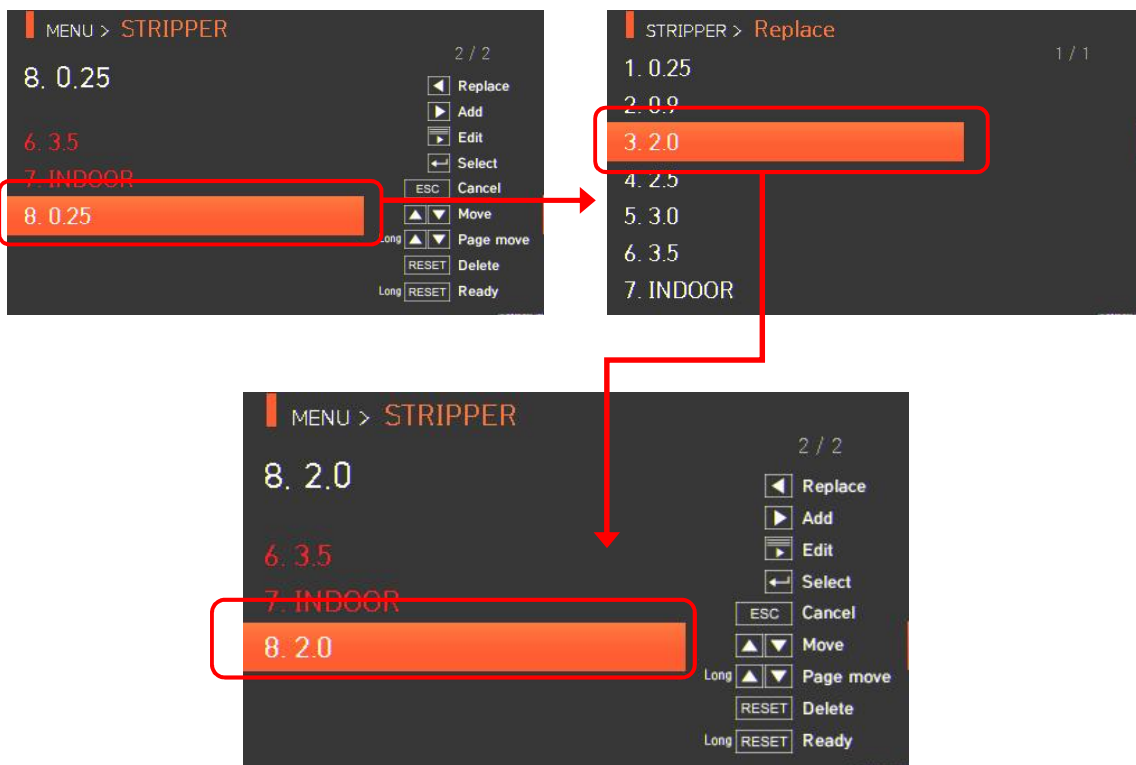

6.3.2 Replacement

Select a stripper mode to replace and press to display stripper modes on the screen. and then the stripper modes saved on the database are displayed on the screen. Select a stripper mode to replace and press , and the mode is replaced with the new mode.



General modes Nos. 1~7 cannot be replaced.

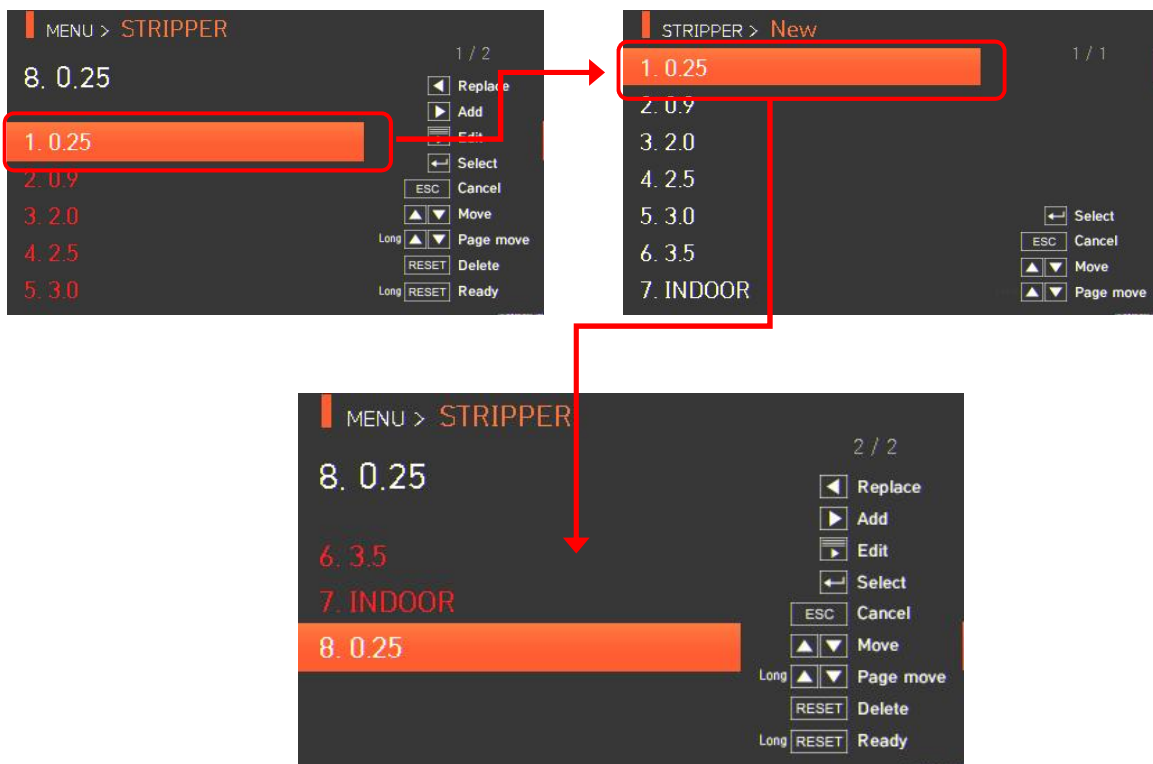

6.3.3 Addition

Press  and stripper modes saved on the database are displayed on the screen. Select a stripper mode to add and press , and the mode is added. The newly added mode is located by the last number.



Any additions cannot be made on general modes no. 1~7.

6.3.4 Edition

Select a splice mode to edit with  and press  and then different set values of the selected stripper mode are displayed. Press a set value and change it into the proper one.

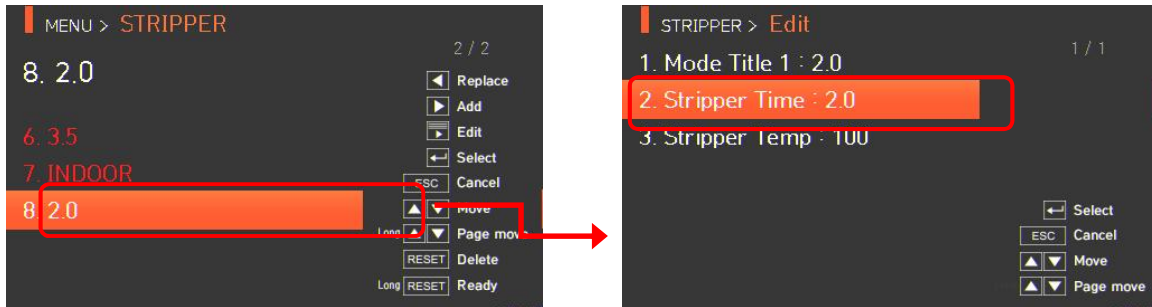

6.3.5 Selection

Press  and the selected stripper mode is saved on the memory and it is used when operating the heater.

6.3.6 Close

Press  and it goes back to the previous stage.

6.4 HISTORY (Splice result)

To display splice mode, press . Select "HISTORY" menu with button to display splice result menu. The HISTORY menu is equipped with various functions for a user to identify and delete splice result and images.

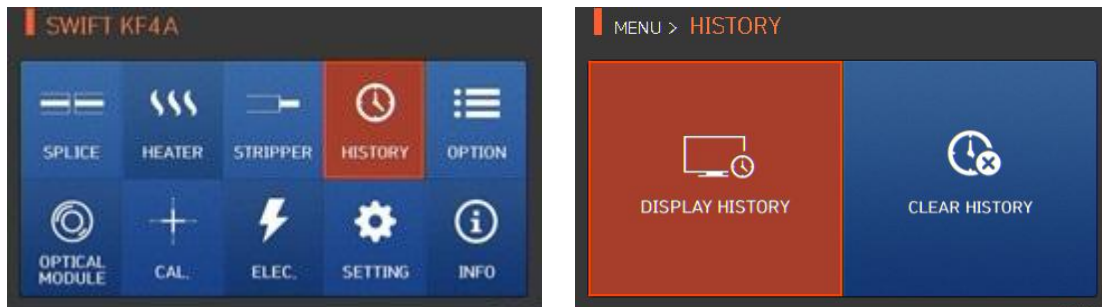

6.4.1 Splice result display

The splicer can save up to 5,000 splice data and images.

Each page shows seven splice data and images. Use to advance screens.

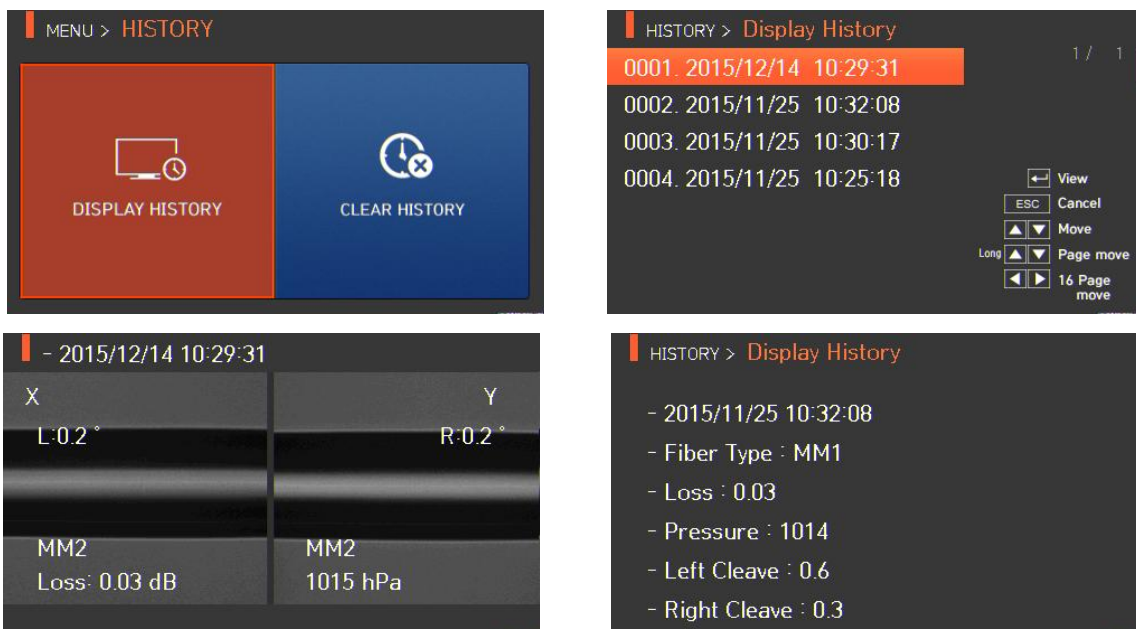

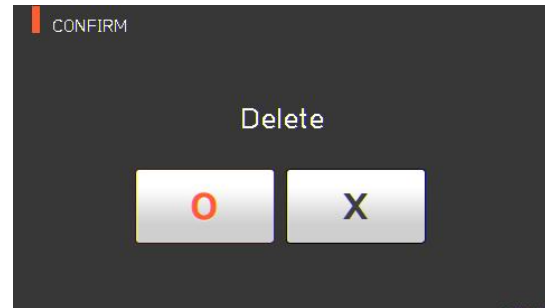
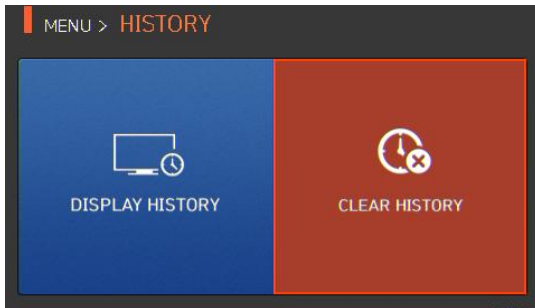

6.4.2 Deletion of splice result

Data and images can be deleted in a single step.



6.5 Option



To display options menu, press  and then select “OPTION” menu with  button. This displays options menu as follows.

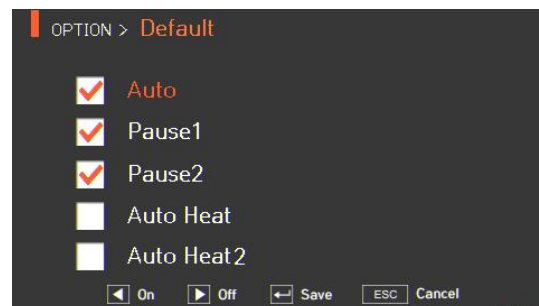
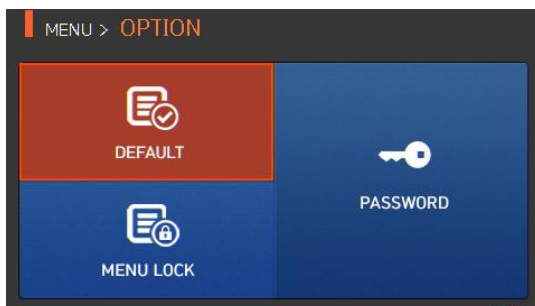

6.5.1 Splice operation

Splice operation consists of 4 sub-checkboxes. As the user marks a checkbox, and each function is activated.



SET VALUE	DESCRIPTION
Auto	Splice automatically starts when closing the wind cover.
Pause 1	It temporarily stops after the first alignment is finished. Press  to advance to the next step.
Pause 2	It temporarily stops after clad alignment is finished. Press  to advance to the next step.
Auto Heat	Heater automatically operates after splice is finished.
Auto Heat2	After installing the sleeve, Heater automatically operates when the heater cover is closed.

6.5.2 Menu lock

This menu includes a function to restrict access to the splice mode and heater mode settings. There is also a function to disable the deletion of the splice result. After activating this lock function, access to the menu lock can also be restricted. Password entry is required to release this restriction; memorize the password. If you forget the password, send the equipment to UCLSWIFT to reset the password.

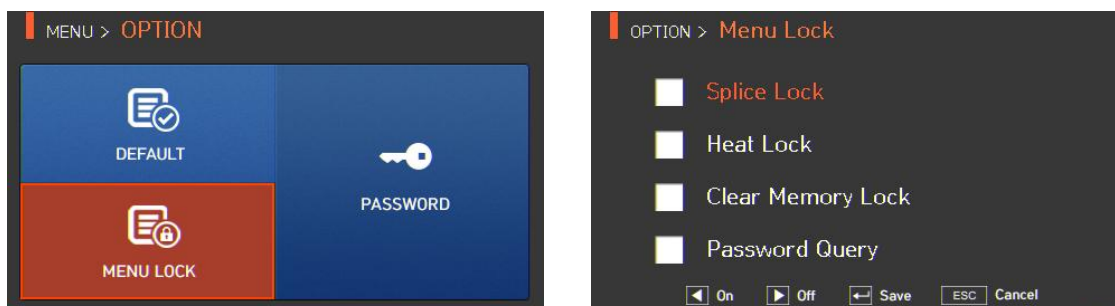

TEST ITEM	DESCRIPTION
Splice Lock	Restricts modification on splice mode.
Heat Lock	Restricts modification on heater mode.
Clear Memory Lock	Restricts deletion of splice result.
Password Query	Shows a screen to enter your password. The initial password is "1234."

6.5.3 Password

The password can be changed as follows.

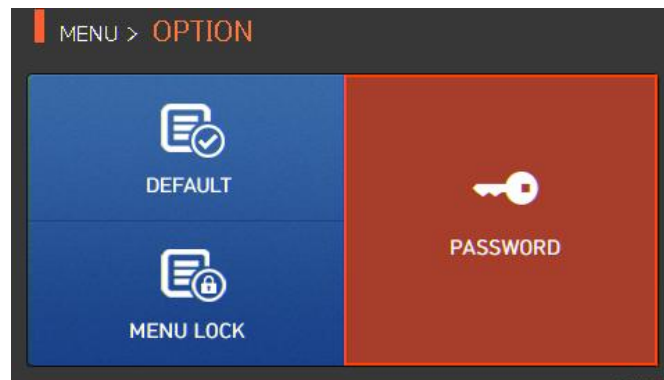

- i. Enter the current password. The initial password is “1234.”



- ii. Enter a new password.



- iii. Enter the new password again.



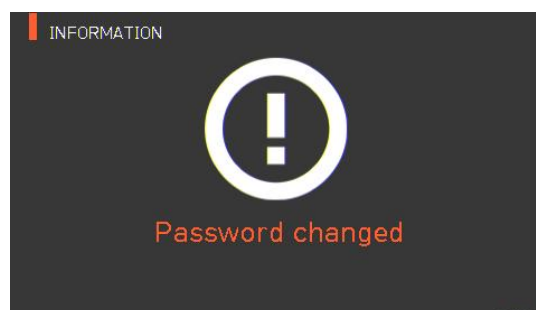
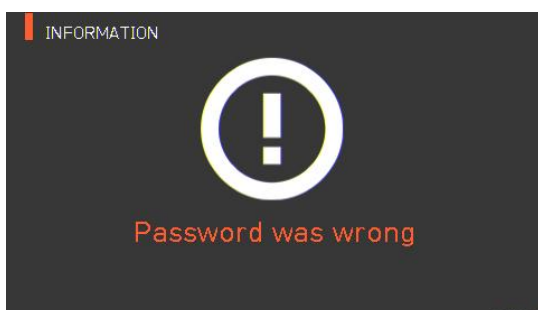

When the entered password does not match, the following message is shown and it goes back to the previous stage.



Memorize the password. If you forget the password, the equipment should be returned to UCLSWIFT to reset the password.

6.6 Optical module

To display the optical module, press  and then select “Optical module” menu with  button. It displays a screen for the optical module menu as follows. Optical module menu is equipped with functions such as information on optical power meter and V.F.L., etc.



6.6.1 Optical power meter

Press “Optical power meter” and it shows the following screen. You can check information on optical module power meter.



- Tone: Displaying frequency of light source
- Continuous: State turned on at all times without frequency of light source
- Others: Displaying the corresponding frequency (270, 330, 1K, 2K by unit of Hz)
- Wavelength: Displaying wavelength of light source
- Optical power: Displaying power of light source, marking default dBm and mW
- dBm/dB: Selecting which of dBm or dB to be used in displaying power of light source
- Upon marking with dB, the reference is also marked simultaneously.
- Save: Saving measured values of light source that are currently being measured
- Ref. (Reference): Setting reference value upon marking with dB
- W/L(Wavelength): Making changes on wavelength of light source
- Menus moved with left and right keys and operation performed with the enter key

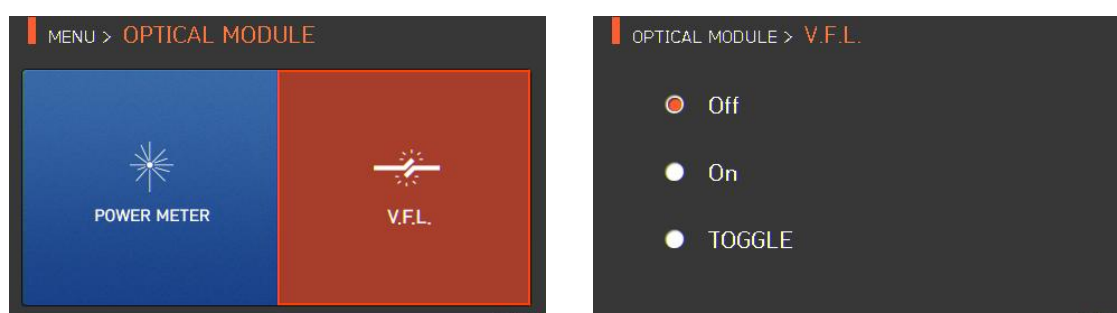

6.6.2 V.F.L.



- i. Connect SOC to V.F.L and check whether the fiber is disconnected with the disconnection check being turned on.
- ii. Upon flickering, V.F.L is activated with 2~3 Hz.
- iii. When you finish using V.F.L, turn it back to the off state.

Blindness can be incurred when you see the light output from V.F.L with naked eye so please be careful.

6.7 Calibration

To display splice mode, press  and select the “CALIBRATION” menu with the  button. The calibration menu is equipped with various functions, such as arc amount calibration, motor operation test, etc.



6.7.1 Arc calibration

Swift KF4A continuously checks if there is a change in temperature and the air pressure through each sensor. Based on such data, arc amount is automatically adjusted. A change in arc amount due to abrasion of the electrodes or the fiber splice, however, is not automatically adjusted. The central axis of arc can also be moved towards the left or right with a large amount of arc. In this case, arc calibration is required.



When executing arc calibration, arc voltage is automatically changed to a proper value. This value is calculated internally; the arc voltage cannot arbitrarily be changed.

Only SM fiber should be used for arc calibration.

i. Prep and insert SM fiber into the splicer using clamps or proper fiber holders.

ii. Press  as follows.

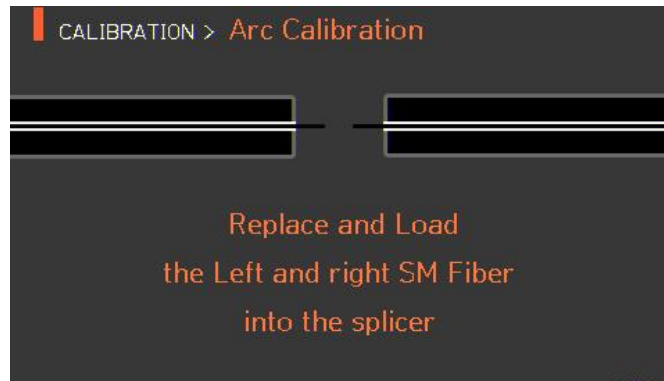

iii. When arc calibration completes, the following screen is displayed.



iv. Press  to stop arc before calibration is completed if necessary.

6.7.2 Arc Test

Swift KF4A measures by ARC TEST menu if arc power is proper. When arc power is too weak or too strong it is automatically adjusted by executing ARC CALIBRATION menu.

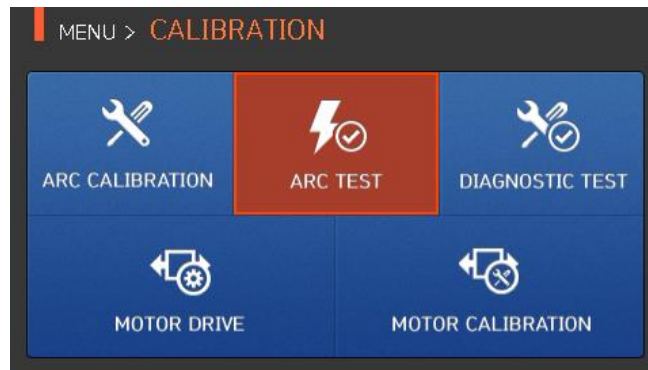

- Only SM fiber should be used for arc calibration.
 - i. Prep and insert SM fiber into the splicer using clamps or proper fiber holders.
 - ii. Press  as follows.

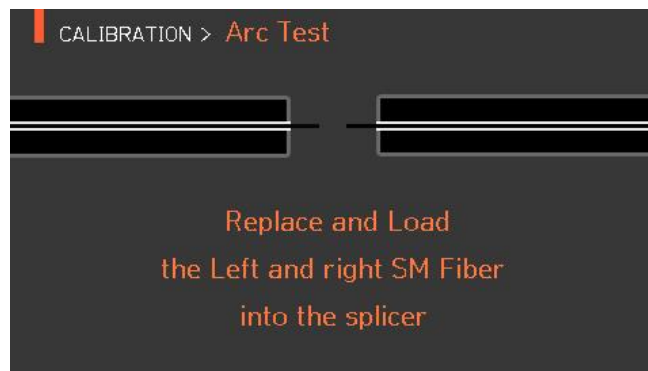

- iii. When arc test completes, the following screen is displayed.

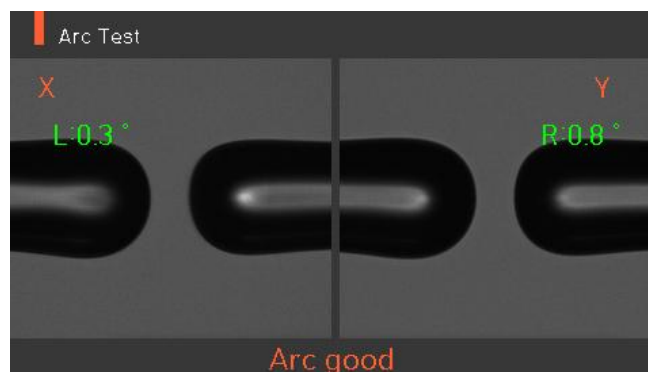

- iv. Press  to stop arc before test is completed if necessary.
- v. Arc Test Result

TEST RESULT	DESCRIPTION
Arc Good	The current arc amount is proper
Arc too weak	The current arc power is too weak and needs Arc Calibration
Arc too strong	The current arc power is too strong and needs Arc Calibration

6.7.3 Diagnostic test

The diagnostic test is a function to facilitate dust examination, LED examination and motor test and calibration at a time.







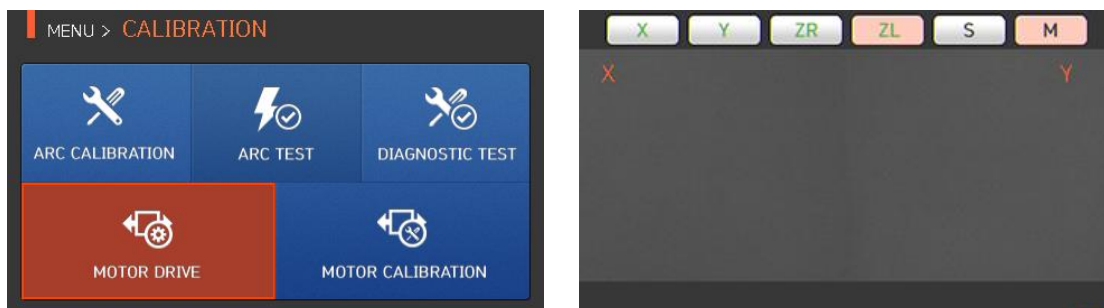

TEST ITEM	DESCRIPTION
Dust Testing	Conducts dust test without fiber
LED Testing	Conducts LED test without fiber
Motor Testing	Conducts motor test
Heater Testing	Conducts heater test

6.7.4 Motor drive

Motor drive checks whether the motor operates normally in manual mode.





- i. Remove the fiber from the splicer.
- ii. Select "MOTOR DRIVE" with  button.
- iii. Change the motor selection by pressing . The name of the selected motor is indicated at the top of the screen.
- iv. Operate the motor in a direction wanted by pressing  .

Motor		
X/Y	Moves fiber down	Moves fiber up
ZL	Moves right fiber backward	Moves right fiber forward
ZR	Moves left fiber forward	Moves left fiber backward
S	Moves step by step upon every press of the button	
M	Continuously moves upon pressing the button	

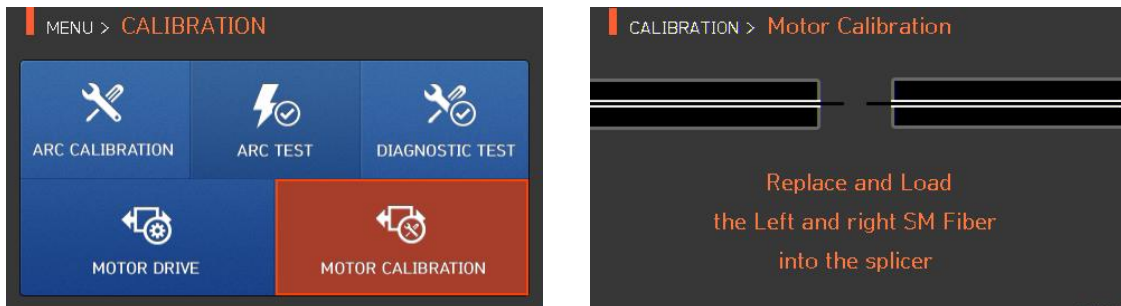

6.7.5 Motor Calibration

Motor setting is set on splicer as default but depending on motor setting location, splice speed may slow down. If the speed slows down during the splice operation or any abnormality is incurred while in the entering position, the motor setting can be automatically calibrated through this function.



- i. Put the fiber on the splicer.
- ii. Select "Motor calibration" with  button.
- iii. If an error message is displayed after testing, immediately contact UCLSwift.
- iv. End the calibration by pressing .

6.8 Electrodes

To display electrodes mode, press  and then select “ELEC” menu with  button. It displays a screen to select electrodes menu as follows. For using the splicer, it should be regularly cleaned due to electrodes abrasion and precipitation of silica oxide. This menu is related to checking electrodes use count and electrodes exchange and includes 4 submenus.

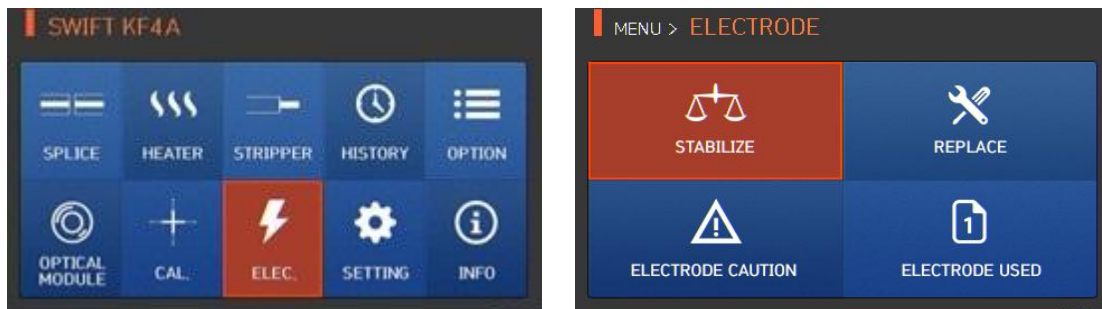

6.8.1 Electrodes Stabilize

Arcing can sometimes become unstable due to surroundings and consequently, the splice loss may increase. As it takes a long time to stabilize arcing when the splicer is located at low or high elevations, it is particularly important to wait for the electrodes inside to be stabilized. After replacing the electrodes, in particular, its stabilizing should be conducted.

- i. Put a prepared fiber on the splicer.
- ii. Select “STABILIZE” with  button.

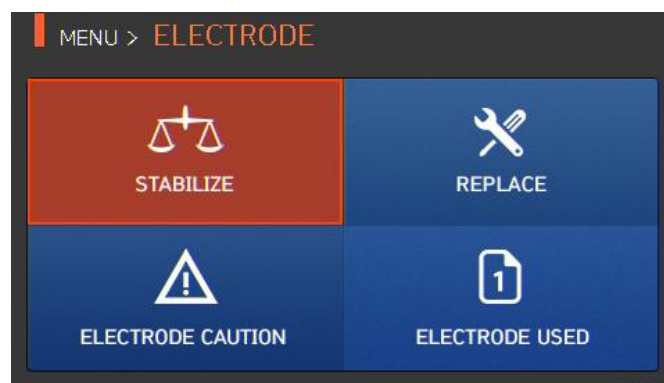

- iii. Press “OK”.

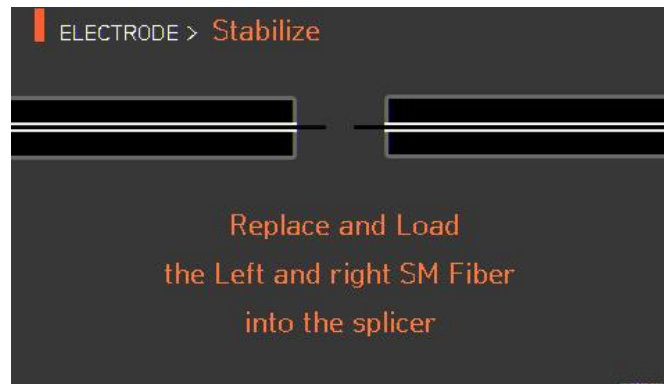

- iv. Arc is conducted 30 times in a row for electrodes stabilizing.
- v. When stabilizing completes, it displays the screen below.



- vi. After stabilizing the electrodes, the arc calibration should be conducted again.

6.8.2 Electrodes Replace

It is recommended to replace an electrodes when the number of arc reaches 4,000 times. When it exceeds the preset number of times for replacement, a message informing electrodes replacement is displayed.

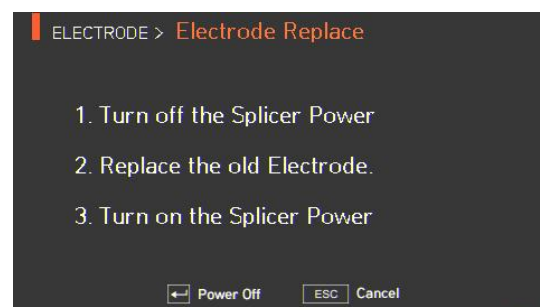
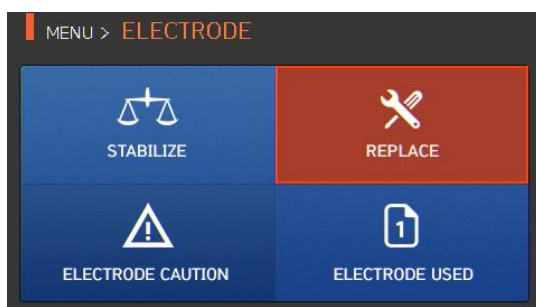

6.8.3 Electrodes Caution

The number of times to inform electrodes replacement is set on this menu. It is recommended to replace an electrodes when its use reaches 4,000 times.

The number of times is the maximum number possible in the optimal environment.

Depending on your work environment, it may be possible to use more than the default number of times

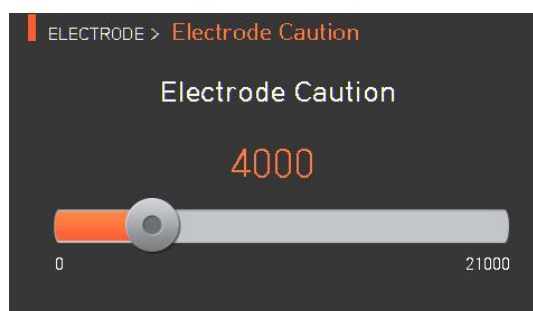
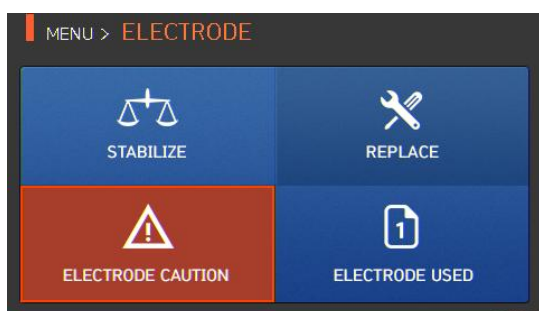

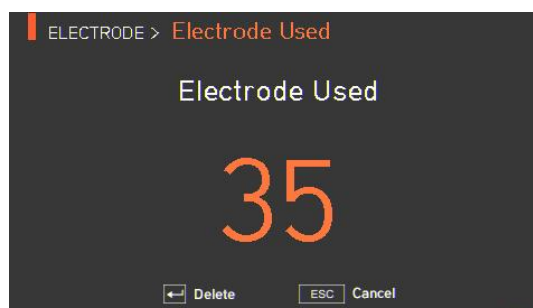
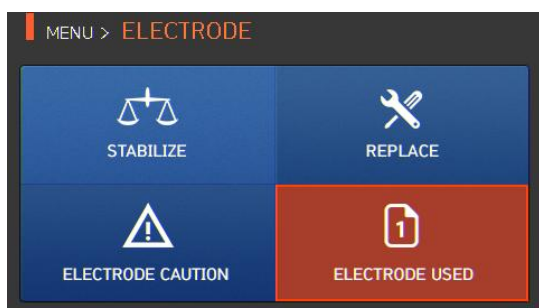

6.8.4 Number of Electrodes Use

It indicates the number of electrodes used as counted up to the present time.



6.9 Setting

To display setting mode, press  and then select "Setting" menu with  button. It displays a screen to select setting menu as follows.



6.9.1 Language

A screen to select a language is displayed.

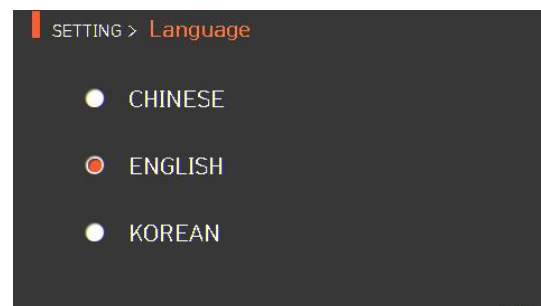
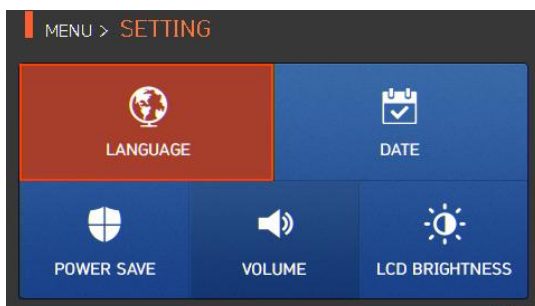

6.9.2 Date

A screen to set the time and date is displayed.

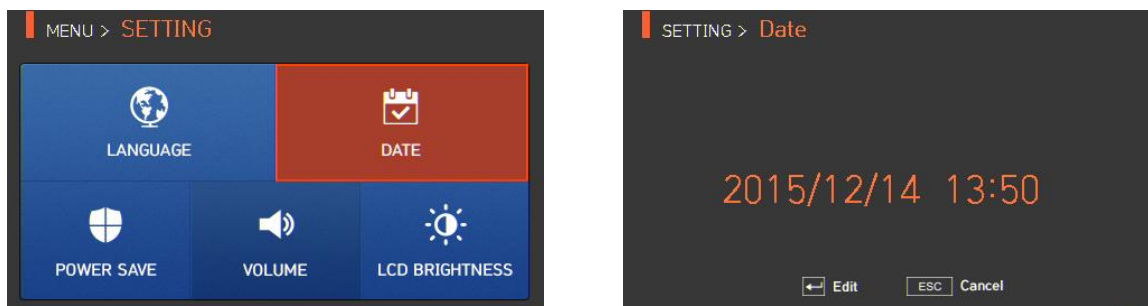

6.9.3 Power Save

Power save is an important function used in order to save energy. As it extends a user's operation time when operating Swift KF4A with a battery, it is recommended to use "Power Save".

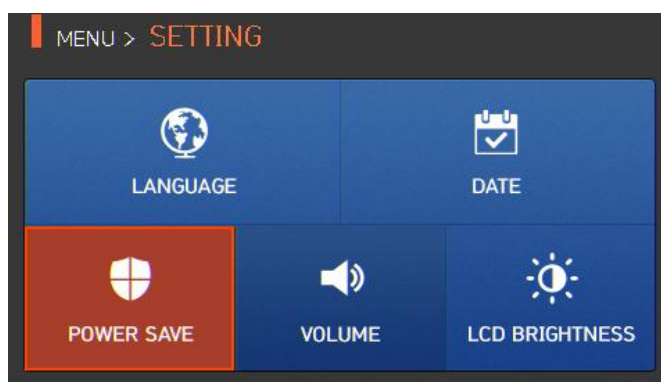

6.9.4 Monitor

When Swift KF4A is not used for a preset time period, the LCD screen automatically turns off. With the push of any button, the screen turns on again

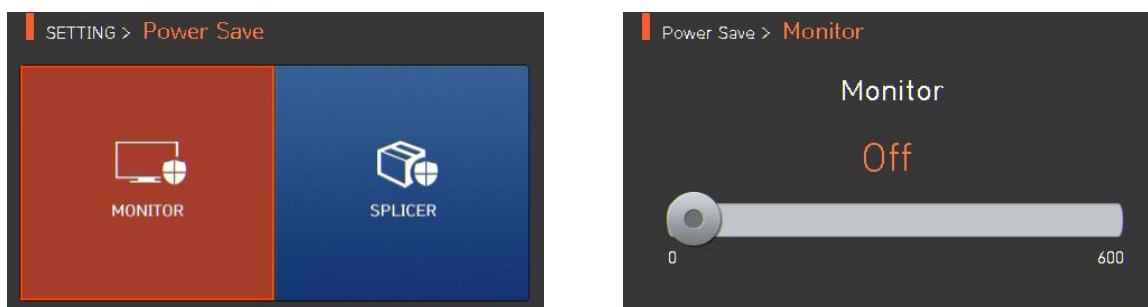

6.9.5 Splicer

When Swift KF4A is not used for the preset time period, power is automatically turned off.

The power is turned on again only when pressing

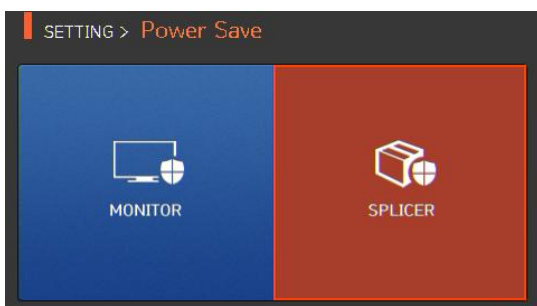

6.9.6 Volume

It adjusts the loudness of the buzzer sound.

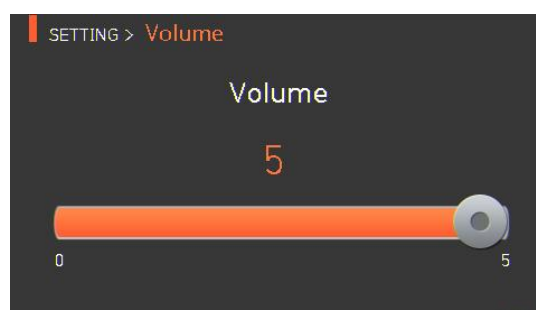
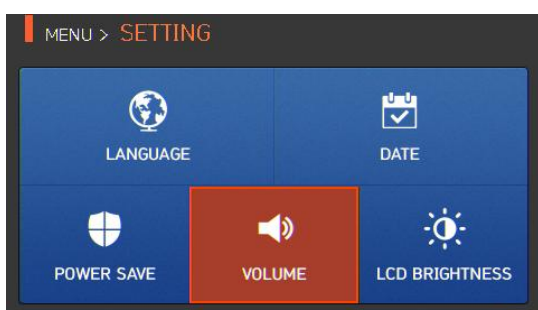

6.9.7 LCD Brightness

It adjusts LCD Brightness.

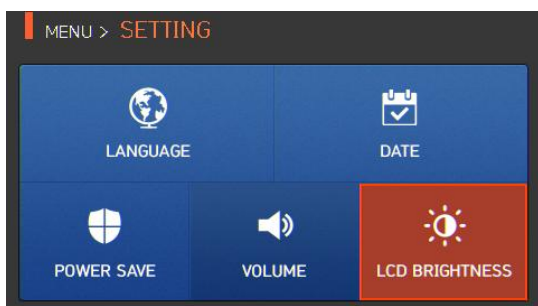

6.10 Information

To display information mode, press and select “INFO” menu with button. It displays a screen to select information menu as follows. This menu provides information for maintenance.



6.10.1 Maintenance

Press “MAINTENANCE” and it displays the screen below.

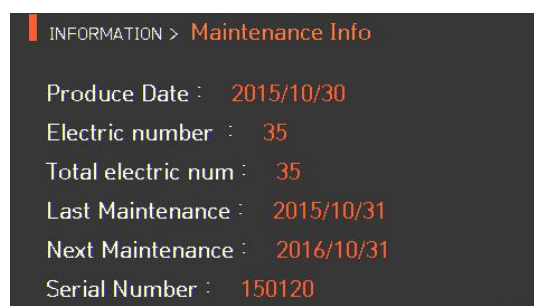
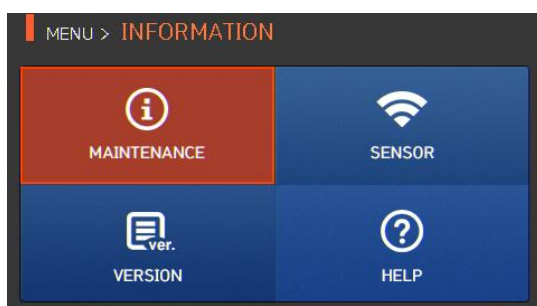

ITEM	DESCRIPTION
Produce Date	Describes the date of the equipment’s manufacture (year, month, day).
Electric Number	Indicates the number of the arc after electrode replacement.
Total Electric Number	Indicates the total amount of arc after the product’s release.
Last Maintenance	Indicates the date of recent maintenance.
Next Maintenance	Indicates the next maintenance date.
Serial Number	Indicates serial number given to the equipment.

6.10.2 Sensor

Press the “SENSOR” and it displays the screen below.

Splicer has sensors to check the temperature, air pressure

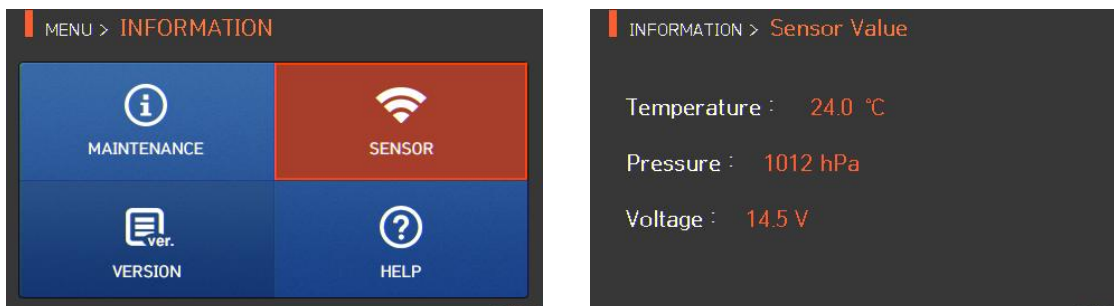

6.10.3 Version

Press “VERSION” and it displays the screen below.

The version can be upgraded easily by connecting to a PC and using the DataSync program (PC Program).

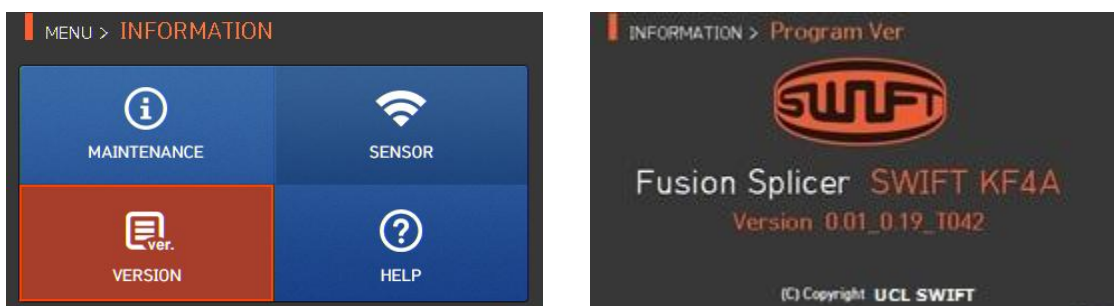

6.10.4 Help

Press “HELP” and it displays the screen below.

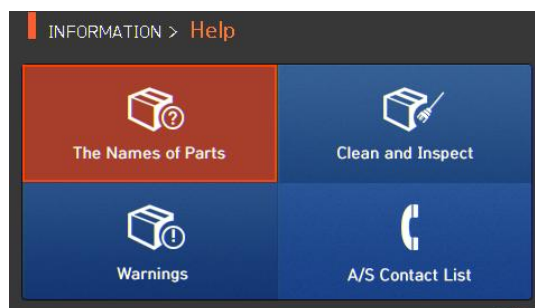
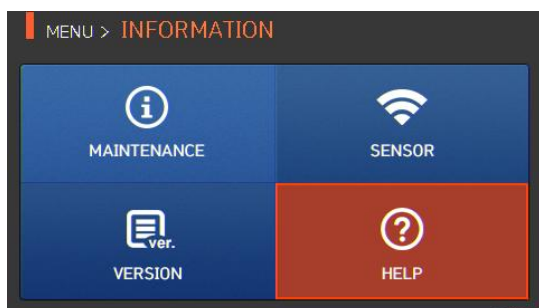

ITEM	DESCRIPTION
THE NAMES OF PARTS	Names of each component on the KF4
CLEAN AND INSPECT	Cleaning and inspection method
WARNINGS	Important warnings
A/S CONTACT LIST	Contact information for warranty

7. Error message

7.1 Too Dirty Fiber

Error message generated when the fiber prepared for splicing contains foreign substances that exceed a normal level.

Solution: Repeat splice after cleaning the fiber.



7.2 Replace Fiber.

It is an error message generated when the fiber is not located in the right location or there is a foreign substance on the object lens or reflector.

*Solution: Press **RESET** and put the fiber on the right location again. Clean the object lens and reflector.*

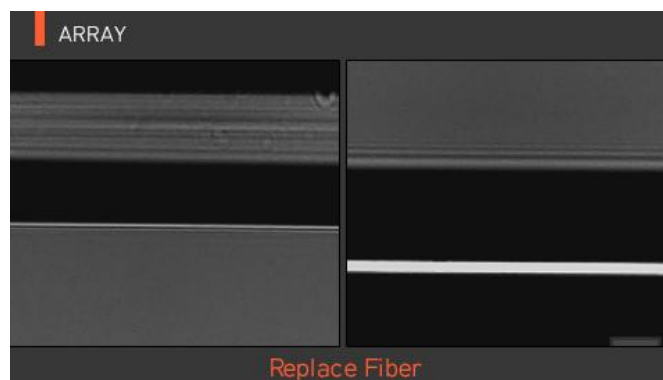

7.3 Too Long Fiber.

It is an error message generated when the fiber is located too close to the electrodes; object lens or reflector is dirty or the LED is not sufficiently bright enough.

*Solution: Press **RESET** and put the fiber on a right location yet again. Clean the object lens and reflector. Conduct LED test. If an error occurs upon performing the LED test, contact UCLSwift.*

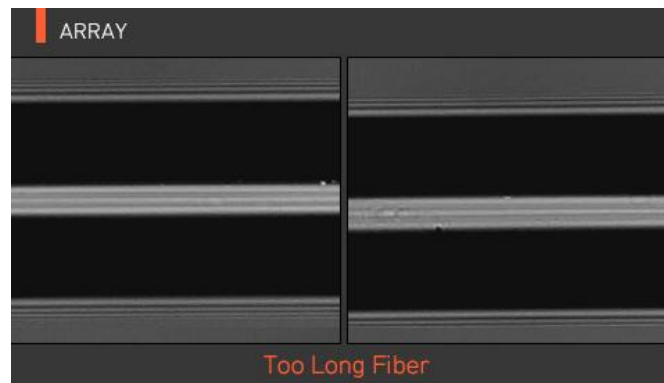

7.4 Fiber over angle

Error message generated when the cleaved angle of the fiber is higher than specified.

Solution: Check the state of the fiber cleaver. Check the cleaved angle limit.

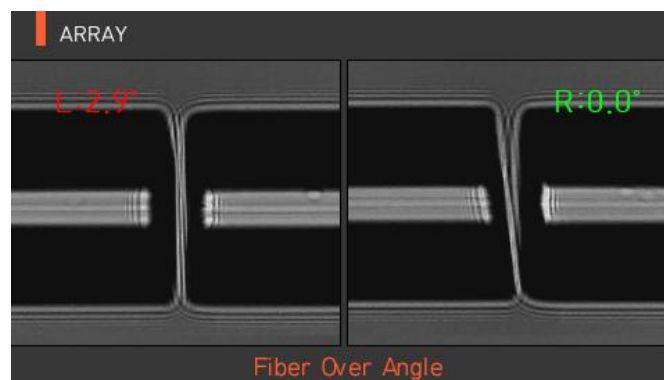

7.5 Loss limit over

Error message generated when the estimated loss value is higher than the preset loss factor limit.

Solution: Check the loss factor limit.

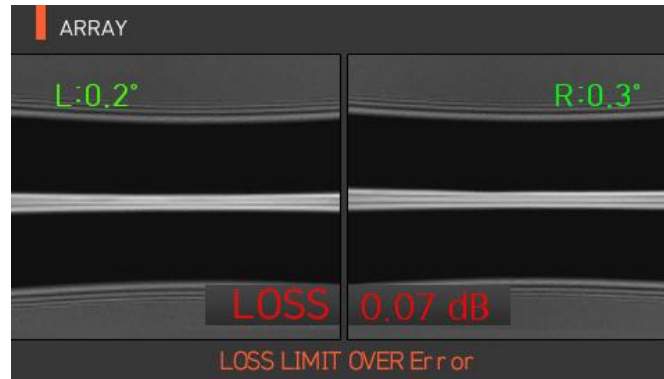

7.6 Fiber thin error

Error message generated when the spliced point becomes thinner than the standard after splicing.

Solution: Make an adjustment to shorten the pulling length of the pulling splice. Check whether the arc amount or arc time is set as too large or too long.

7.7 Fiber thick error

Error message generated when the spliced point becomes thicker than the standard after splicing.

Solution: Reduce the overlap set value. Check whether the arc amount or arc time is set as too small or too short.

7.8 Bubble error

Error message generated when there are bubbles or spots being generated on spliced point after splicing.

Solution: Examine the fiber cleaver. Clean the V-groove. Examine the electrodes.

7.9 Cleaved surface error

Error message generated when the cut surface of the fiber is of poor quality.

Solution: Check the condition of the fiber cleaver. Re-cleave the fiber.

8. Splicing problem solving

8.1 When loss is high

- **Any dust or foreign substance on the fiber surface may cause a poor splice.**
 - Clean the fiber surface sufficiently.
 - Do not clean the fiber after cleaving to prevent dust from being gathered in the fiber cross section.
 - Lower fibers into V-grooves rather than pushing in from the sides. Fiber holders will facilitate proper insertion.
- **Any foreign substance on V-groove hinders the correct alignment.**
 - Keep the V-groove clean at all times.
- **Electrode condition.**
 - When an electrode contains an abrasion or its tip is bent and dirty, replace the electrodes.
- **Arc amount and arc time are inappropriate.**
 - Check the setting of arc amount and arc time to reset them with proper values.
 - Changes in arc time and amount are generally considered to be minor adjustments to factory settings.
- **Inappropriate splice mode.**
 - Check whether appropriate splice mode is selected for the fiber

8.2 Abnormal splicing operation

- **Alignment operation is repeated.**
 - Open the wind cover again and then close.
 - If discontinues, open the wind cover, press  and then turn off the power and contact UCLSWIFT.
- **The error message “Too Long Fiber” is continuously generated.**
 - Turn off the power and contact UCLSWIFT.

9. Problem occurrence and question

9.1 Power

- **Power is not turned on by pressing .**
 - Check whether the screen is turned off with the switch being pressed for about 1 second.

- **Cannot continue splicing after several times of splices even with the fully charged battery.**
 - Power is quickly consumed when "Save mode" is not in use. Refer to the Save Mode to assure proper settings.
 - If the battery's life ends for long-term use, replace it with approved replacement. Battery wattage drops with low temperature and more rapidly with temperatures below zero. Also, splice current consumption goes up with high temperature and battery's power consumption accelerates.

- **LED is not turned on upon charging.**
 - Disconnect the charger's AC power cord and connect the DC cord to the charging jack.
 - Connect the AC power cord after 10~15 seconds. Then the battery's LED is turned on red and charging starts.

- **No remaining battery indication.**
 - Charge the battery.

- **Remaining battery is not well displayed.**
 - Remaining battery display is for reference.

9.2 Splice

- **The error message displayed on the screen.**
 - Refer to the Error message list.

- **Splice loss is high or irregular.**
 - Clean V-groove, V-block, reflector and object lens by referring to [Maintenance of splice quality]. Replace electrodes by referring to [Electrodes replace]. Refer to the "High estimated loss" from [Error message list].
 - If fiber warps or is bent, place the fiber bent direction to face the bottom. Splice loss varies depending on cleaving angle, arc condition and cleanliness level of fiber. If splice loss is still high or irregular even after implementing these recovery measures, contact UCLSWIFT. Annual maintenance is required to maintain optimal splice quality.

- **The monitor is suddenly turned off.**
 - Refer to [Monitor sleep mode menu].

- **Power is suddenly turned off.**
 - Refer to [Splicer sleep mode menu].

- **Either arc amount or arc time does not change.**
 - On SM, NZ, MM or AUTO mode, either arc amount or arc time does not change. Implement [Arc Calibration] and the arc amount on these modes properly maintain. When used in another mode, arc amount and arc time are automatically set to prevent their alteration.

- **Set pause.**
 - Refer to [Option menu].

- **Indicate cleaved angle, fiber angle, and clad deviation.**
 - Refer to [Option menu].



- **Estimated splice loss and measured splice loss do not match.**
 - The estimated splice loss is a calculated value so it should be used only as a reference.

9.3 Sleeve heater

- **Fiber protecting sleeve does not contract completely.**
 - Increase the heating time. Refer to [Heater mode edition].

- **The heater is overheated.**
 - Stop the heater by pressing , turn the power off and then contact UCLSWIFT.
 - If the protecting sleeve melts and sticks to the heater cover, remove it by pushing it with a cotton swab.

- **Initialize heater mode condition.**
 - Refer to [Heat mode edition].

- **Cancel heater in the middle of an operation.**
 - Heater operation cannot cancel by pressing . Cancel it by pressing  once again.

9.4 Others

- **Restrict splice mode and heater mode setting.**
 - Refer to [Menu lock].

- **Splice mode's arc amount does not change even after [Arc calibration].**
 - The internal standard arc amount does calibrate; therefore, the arc amount of each splice mode does not change.

- **Forgotten password.**
 - Contact UCLSWIFT.

10. Warranty and Repair

Responsibility limit

UCLSwift guarantees its product regarding the product's material and flaws from the manufacturing. With normal use and service, we guarantee the entire hardware of the product for the term of guarantee. When a problem is incurred during the term of guarantee, the product is to be repaired or exchanged free of charge by UCLSwift's own judgment. When ~~a~~ flaws or damages are incurred for any of the reasons listed below, the repair expense may be charged to the customer even under warranty.

- i. Natural disaster
- ii. Abnormal voltage supply
- iii. User's careless handling
- iv. Product handling with disregard on working procedure or directions written on instructions for use
- v. Consumables (electrodes, etc)

10.1 Information necessary for repair

Before sending the product, contact UCLSWIFT first.

- i. Company and contact information
- ii. (Name, department, company, address, contact information, fax, email)
- iii. Product serial number
- iv. Product condition and problem incurred, error information
- v. Operating conditions, processes and uses of the splicer prior to error

10.2 Transportation

Please return the splicer in the carry case provided to protect it from humidity, vibration and shock. Include all components in the case.

10.3 Repair Customized modes, configurations and splice data may be lost during repair. Save test data prior to shipment to ensure retention.

Product Warranty

Product name	SWIFT KF4A		
Manufacture no.			
Date of purchase			
Customer	Name		Tel.
	Address		

Warranty

1. This product is manufactured through strict quality management and inspection.
2. This product guaranteed for one year over defective parts from its date of purchase.
3. Present this product warranty card when repair is required for the product.
4. As this product is a high-precision device, please carry it in the carry case at all times to protect it from humidity, vibration and shock.

Charged service

In the following cases, a service fee (repair, component and travel expenses) is charged even under warranty.

1. Breakdown or damage due to natural disasters
2. Breakdown or damage due to abnormal voltage supply
3. Breakdown or damage due to user's careless handling
4. Breakdown or damage due to product handling with disregard to the working procedure or directions written on instructions for use
5. When the seal is damaged

❖ When maintenance is required, contact IIsinthe or local sales representatives